



EPLAN P8

Elektrodokumentation Electrical documentation

Hersteller:
Manufacturer: Boll & Kirch Filterbau GmbH
Siemensstraße 10-14
D-50170 Kerpen

Algemeine Daten:
General informations:

BK-Artikel-Nr.: 4301027
BK-Article-No.:

Projektdatei:
Project data:

Zeichnungs-Nr.: Z46859
Drawing-No.:

Typ: Filtertyp 6.49 ME 2.0 DN200
Type:

Bezeichnung: Vollautomatischer Rückspülfilter
Designation: Fully automatic back flushing filter

Anzahl Seiten: 24
Number of pages:

Bearbeiter: ogoericke
Edited by:

Datum: 12.03.2024
Date:

Normen:
Specifications: Ausführung der Schaltanlage nach DIN EN 61439-5:2015-10. Bestimmungen für fabrikfertige Schaltgerätekombinationen mit Nennspannung bis 750V. Nennisolationsspannung 450/750V und Nennspannung 450/750V.
Execution of the switchgear according to DIN EN 61439-5:2015-10. Regulations for factory-fabricated switchgear combinations with rated voltage up to 750V. Rated insulation voltage 450/750V and rated voltage 450/750V.

Technische Kenngrößen
Technical characteristics

Gehäuse:
Enclosure:

Bezeichnung: AX 1039.000
Designation:

Materialtyp: Stahlblech
Material: Carbon steel

Abmessungen: 600 x 380 x 210mm
Dimensionings:

Schutzart: IP65
Degree protection:

Farbe: RAL7035
Color:

Türanschlag: Rechts
Door stop: Right

Montage: Wandabstandshalter
Mounting: Wall spacer

Gewicht: 18,5kg+3,4kg(Box)
Weight:

Leitungsfarben:
Wire colors:

Arbeitsstromkreis: Schwarz
Load circuit: Black

Schutzleiter: Grün/Gelb
Protection conductor: Green/Yellow

Steuerstromkreis: Rot
Control circuit: Red

Fremdspannung: Orange
External voltage: Orange

Verdrahtung
Wiring

Hauptstromkreis wird mit 1,5mm² und Steuerstromkreis mit 1mm² verlegt.
Die Verdrahtung erfolgt von oben nach unten bzw. von links nach rechts gemäß den Stromlaufplänen.
The main circuit is laid with 1.5mm² and the control circuit with 1mm².
The wiring is carried out from top to bottom or from left to right according to the circuit diagrams.

Spannungen:
Voltages:

Betriebsspannung: 3~/PE
Operating voltage: 440V

Frequenz: 60Hz
Frequency:

Steuerspannung: 24V DC
Control voltage:

Sonstiges:
Miscellaneous:

Aderbeschriftung: -
Wire labeling:

Kabeltyp: H07V-K
Cable type:

Netzform: IT
Network types:

Umgebungstemperatur: 55°C
Environment temperature:

Kurzschlussfestigkeit (SCCR): 50kA
Short-circuit strength (SCCR):

Steuergerät: BK2300
Control device:

Getriebemotor: 2x (24VDC/3A)
Gear motor:

Pumpenmotor: 4,55kW/8,00A
Pump motor:

weitere Hinweise:
other notes:

Kabeleinführung: oben unten
Cable entry: top bottom

Hauptschalter: vorne links rechts
Main switch: Front left right

Kundenvorschriften: Ja Nein
Customer specifications: Yes No

REV04	Göricke	06.12.2024	Datum Date	12.03.2024		Hersteller Manufacturer Boll & Kirch Filterbau GmbH	Deckblatt Cover sheet Filtertyp 6.49 ME 2.0 DN200	BK-Artikel-Nr.: 4301027	=	
REV03	Göricke	15.10.2024	Bearbeiter Edited by	ogoeericke				BK-Artikel-Nr.: 4301027	+	
REV02	Göricke	22.04.2024	Auftrag Order					Zeichnungs-Nr.: Z46859	Blatt Page	1
Revision Revision	Bearbeiter Edited by	Datum Date	Vorgang Process					Drawing-No.: Z46859	von of	24

Inhaltsverzeichnis Table of contents

Funktionskennzeichen function identifier	Einbauort Mounting location	Dokumentenart Document type	Seite Page	Seitenbezeichnung Page designation	Datum Date	Bearbeiter Edited by
		Schaltplan Wiring diagram	1	Deckblatt Cover sheet	06.12.2024	ogoricke
		Schaltplan Wiring diagram	2	Inhaltsverzeichnis Table of contents	12.12.2024	ogoricke
		Schaltplan Wiring diagram	3	Inhaltsverzeichnis Table of contents	06.12.2024	ogoricke
		Schaltplan Wiring diagram	4	Einspeisung und Stromversorgung Feed-in and power supply	06.12.2024	ogoricke
		Schaltplan Wiring diagram	5	Platine Circuit board	06.12.2024	ogoricke
		Schaltplan Wiring diagram	6	Bedienfeld + iBoll Modul Control panel + iBoll-Module	06.12.2024	ogoricke
		Schaltplan Wiring diagram	7	Getriebemotoren Gear motors	12.12.2024	ogoricke
		Schaltplan Wiring diagram	8	Pumpe Gear motors	06.12.2024	ogoricke
		Schaltplan Wiring diagram	9	Netzteil Gear motors	06.12.2024	ogoricke
		Schaltplan Wiring diagram	10	Ventil Valve	12.12.2024	ogoricke
		Schaltplan Wiring diagram	11	Sensoren Sensors	12.12.2024	ogoricke
		Schaltplan Wiring diagram	12	Reserve Spare	06.12.2024	ogoricke
		Schaltplan Wiring diagram	13	Aufbauplan Assembling diagram	06.12.2024	ogoricke
		Schaltplan Wiring diagram	14	Aufbauplan Klemmenbox Assembling diagram	06.12.2024	ogoricke
		Materialliste Part list	1	Materialliste Part list	12.12.2024	ogoricke
		Materialliste Part list	2	Materialliste Part list	06.12.2024	ogoricke
		Materialliste Part list	3	Materialliste Part list	12.12.2024	ogoricke
		Klemmenplan Terminal diagram	1	Klemmenplan Terminal diagram	06.12.2024	ogoricke
		Klemmenplan Terminal diagram	2	Klemmenplan Terminal diagram	06.12.2024	ogoricke
		Klemmenplan Terminal diagram	3	Klemmenplan Terminal diagram	06.12.2024	ogoricke

REV04	Göricke	06.12.2024	Datum Date	12.03.2024		Hersteller Manufacturer Boll & Kirch Filterbau GmbH	Inhaltsverzeichnis Table of contents Filtertyp 6.49 ME 2.0 DN200	BK-Artikel-Nr.: BK-Article-No.:	4301027	=
REV03	Göricke	15.10.2024	Bearbeiter Edited by	ogoricke				+		
REV02	Göricke	22.04.2024	Auftrag Order					Blatt Page	2	
Revision Revision	Bearbeiter Edited by	Datum Date	Vorgang Process					von of	24	

Inhaltsverzeichnis Table of contents

Funktionskennzeichen function identifier	Einbauort Mounting location	Dokumentenart Document type	Seite Page	Seitenbezeichnung Page designation	Datum Date	Bearbeiter Edited by
		Klemmenplan Terminal diagram	4	Klemmenplan Terminal diagram	06.12.2024	ogoericke
		Klemmenplan Terminal diagram	5	Klemmenplan Terminal diagram	06.12.2024	ogoericke
		Klemmenplan Terminal diagram	6	Klemmenplan Terminal diagram	06.12.2024	ogoericke
		Klemmenplan Terminal diagram	7	Klemmenplan Terminal diagram	06.12.2024	ogoericke

REV04	Göricke	06.12.2024	Datum Date	12.03.2024		Hersteller Manufacturer Boll & Kirch Filterbau GmbH	Inhaltsverzeichnis Table of contents Filtertyp 6.49 ME 2.0 DN200	BK-Artikel-Nr.: BK-Article-No.:	4301027	=
REV03	Göricke	15.10.2024	Bearbeiter Edited by	ogoericke				+		
REV02	Göricke	22.04.2024	Auftrag Order					Blatt Page	3	
Revision Revision	Bearbeiter Edited by	Datum Date	Vorgang Process					von of	24	

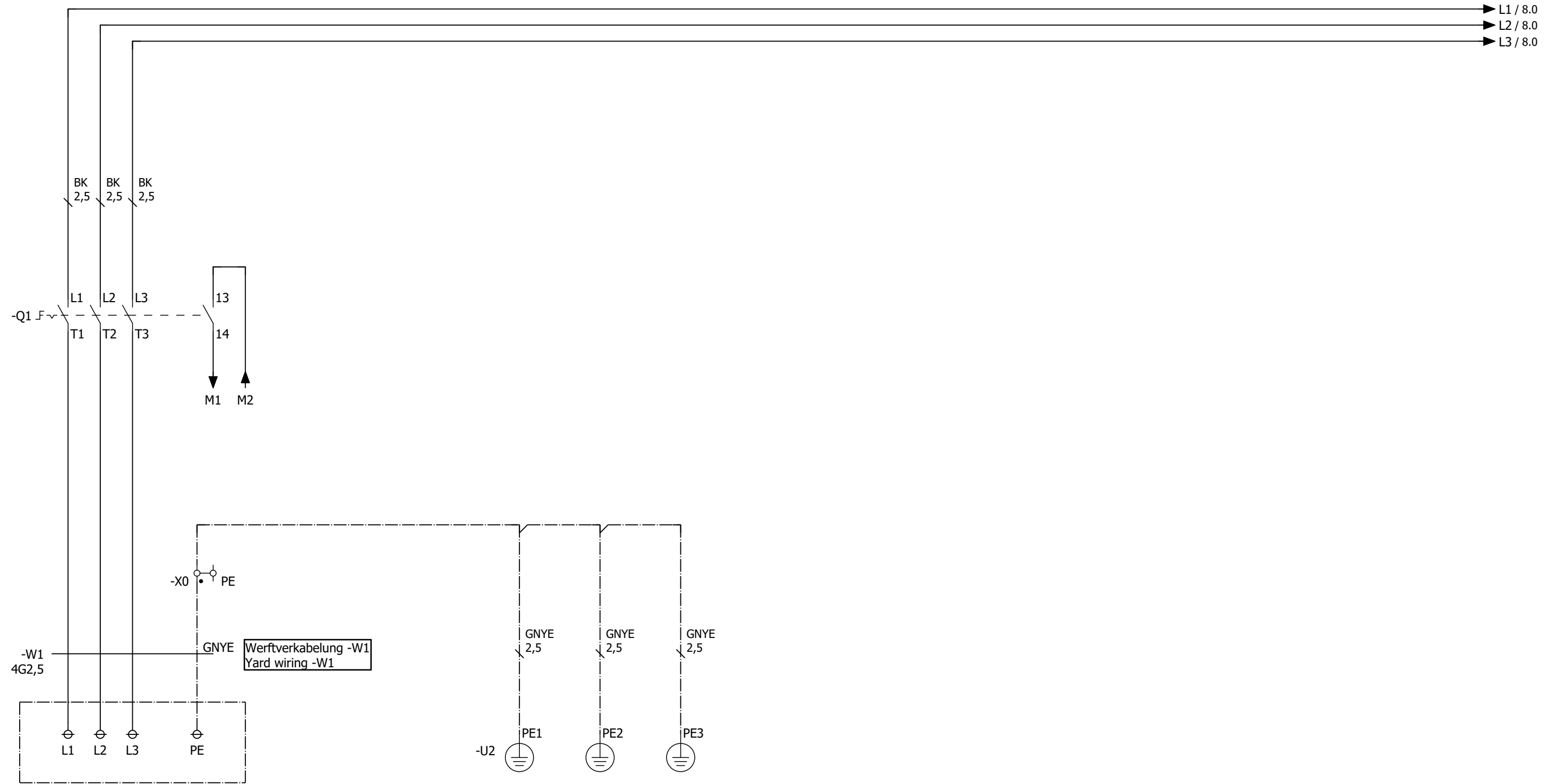

Spannung: 440V
 Voltage:
 Frequenz: 60Hz
 Frequency:
 max. Vorsicherung: Kundenseitig
 max. Pre-protection: by customer

Einspeisung vom Netz
 Power supply input
 from mains

REV04	Göricke	06.12.2024	Datum Date	12.03.2024		Hersteller Manufacturer Boll & Kirch Filterbau GmbH	Einspeisung und Stromversorgung Feed-in and power supply Filtertyp 6.49 ME 2.0 DN200	BK-Artikel-Nr.: 4301027	=	
REV03	Göricke	15.10.2024	Bearbeiter Edited by	ogoeरिकke				BK-Article-No.:		+
REV02	Göricke	22.04.2024	Auftrag Order					Zeichnungs-Nr.: Z46859	Blatt Page	4
Revision Revision	Bearbeiter Edited by	Datum Date	Vorgang Process					Drawing-No.:	von of	24

Hinweis für alle Klemmen der Platine -A2:
 Leiterquerschnitt flexibel, mit Aderendhülse mit Kunststoffhülse: max. 1,5mm²
 Note for all terminals from circuit board -A2:
 Conductor cross section flexible, with ferrule with plastic sleeve: max. 1,5mm²

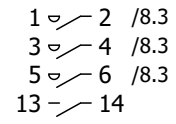
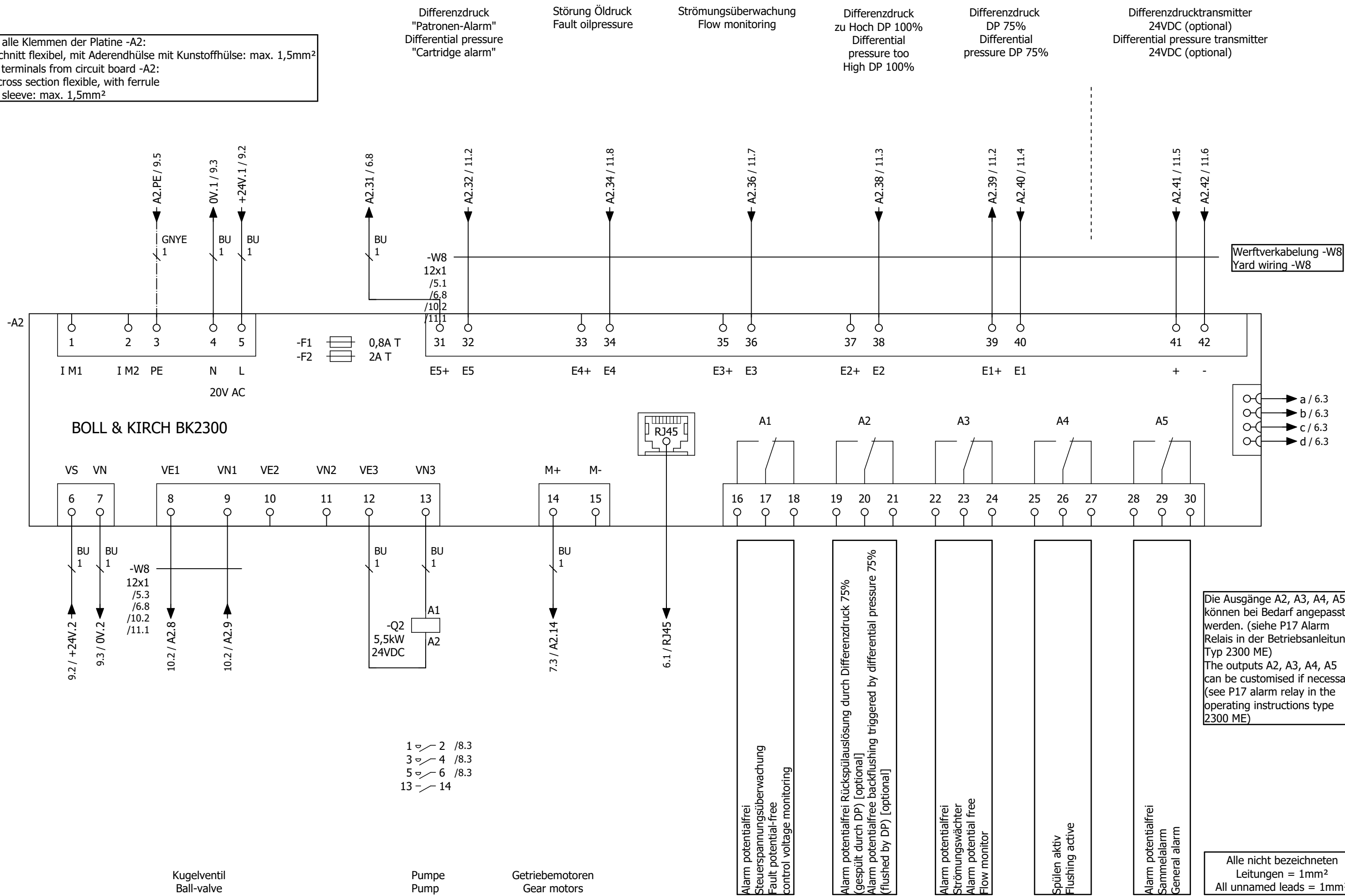

Die Ausgänge A2, A3, A4, A5 können bei Bedarf angepasst werden. (siehe P17 Alarm Relais in der Betriebsanleitung Typ 2300 ME)
 The outputs A2, A3, A4, A5 can be customised if necessary. (see P17 alarm relay in the operating instructions type 2300 ME)

Alle nicht bezeichneten Leitungen = 1mm²
 All unnamed leads = 1mm²

REV04	Göricke	06.12.2024	Datum Date	12.03.2024		Hersteller Manufacturer Boll & Kirch Filterbau GmbH	Platine Circuit board Filtertyp 6.49 ME 2.0 DN200	BK-Artikel-Nr.: BK-Article-No.:	4301027	=
REV03	Göricke	15.10.2024	Bearbeiter Edited by	ogoeरिके				+ Blatt Page	5	
REV02	Göricke	22.04.2024	Auftrag Order					von of	24	
Revision Revision	Bearbeiter Edited by	Datum Date	Vorgang Process							

Störung Getriebemotor 1 Fault gear motor 1
 Störung Getriebemotor 2 Fault gear motor 2
 Störung Pumpe Fault pump
 Störung 3-Wege Ventil 3-way valve fault

Hinweis für Klemme 57:
 Leiterquerschnitt flexibel,
 mit Aderendhülse mit Kunststoffhülse:
 max. 1,5mm²
 Note for terminal 57:
 Conductor cross section flexible, with ferrule with
 plastic sleeve: max. 1,5mm²

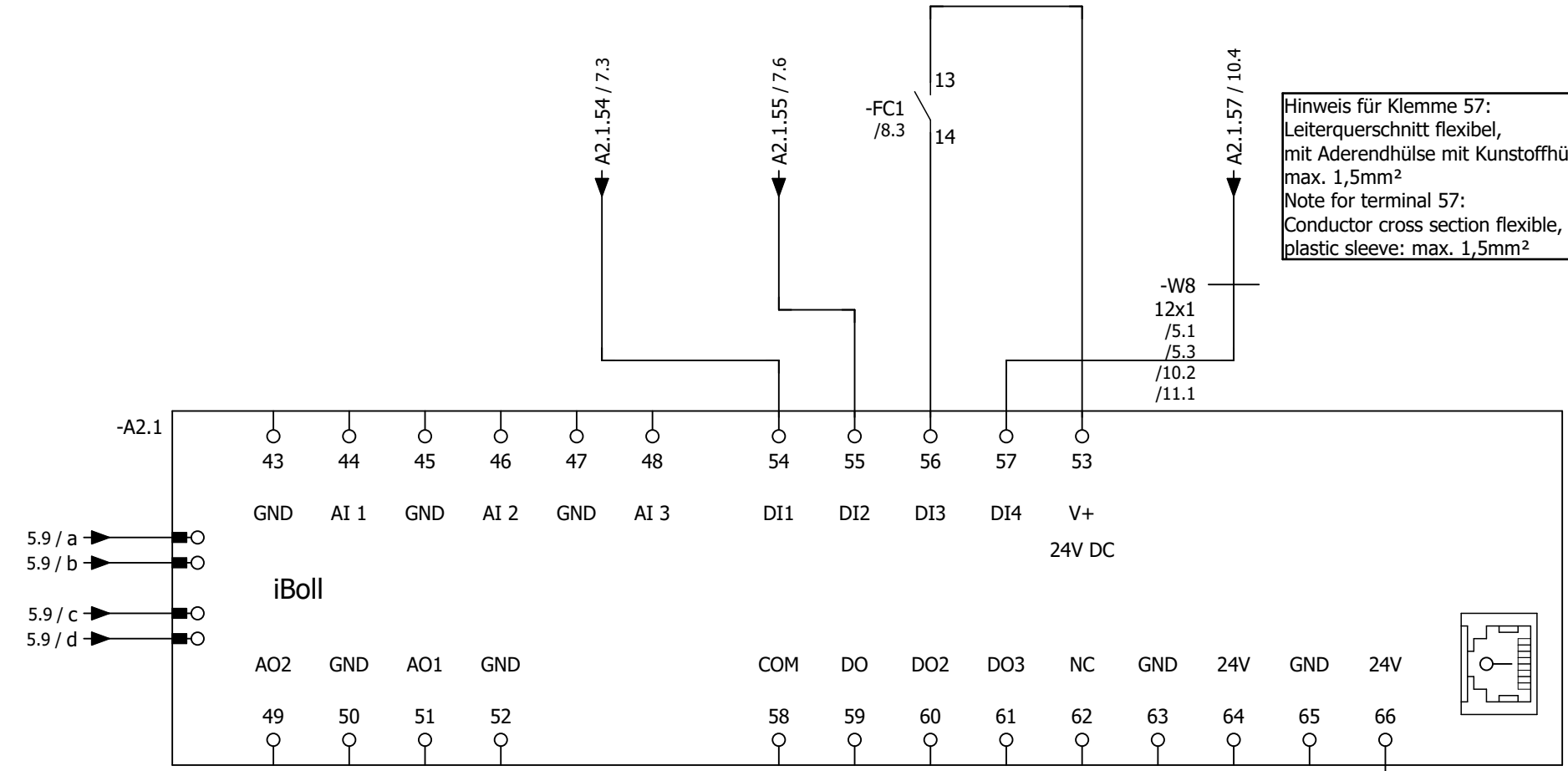
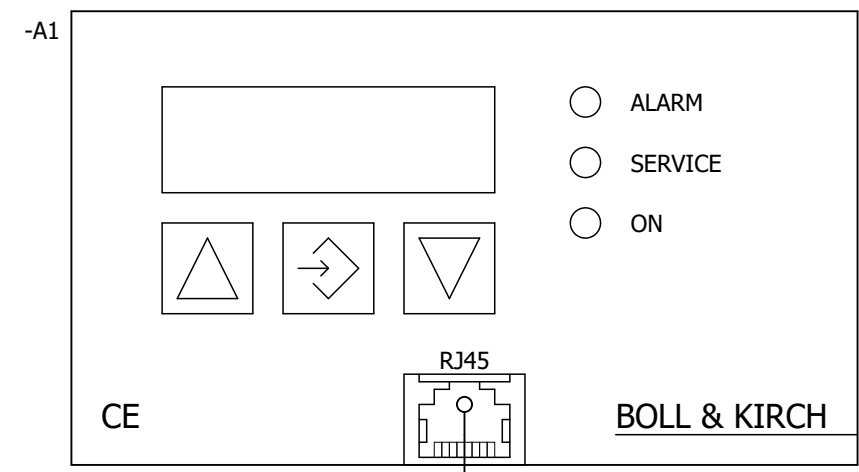

5.5 / RJ45

5.3 / A2.31

Platinensatz für Typ 2300 ME V2.0
 (bestehend aus: Display -A1 / Platine -A2 / Zusatzplatine -A2.1 / Verbindungskabel)
 Card-set for Type 2300 ME V2.0
 (consisting of: display -A1 / circuit board -A2/ additional circuit board -A2.1 / connection cable)
B&K ID 4301028

Alle nicht bezeichneten
 Leitungen = 1mm²
 All unnamed leads = 1mm²

REV04	Göricke	06.12.2024	Datum Date	12.03.2024		Hersteller Manufacturer Boll & Kirch Filterbau GmbH	Bedienfeld + iBoll Modul Control panel + iBoll-Module Filtertyp 6.49 ME 2.0 DN200	BK-Artikel-Nr.: BK-Article-No.:	4301028	=
REV03	Göricke	15.10.2024	Bearbeiter Edited by	ogoeरिके				+ Blatt Page	6	
REV02	Göricke	22.04.2024	Auftrag Order					von of	24	
Revision Revision	Bearbeiter Edited by	Datum Date	Vorgang Process							
								Zeichnungs-Nr.: Drawing-No.:	Z46859	

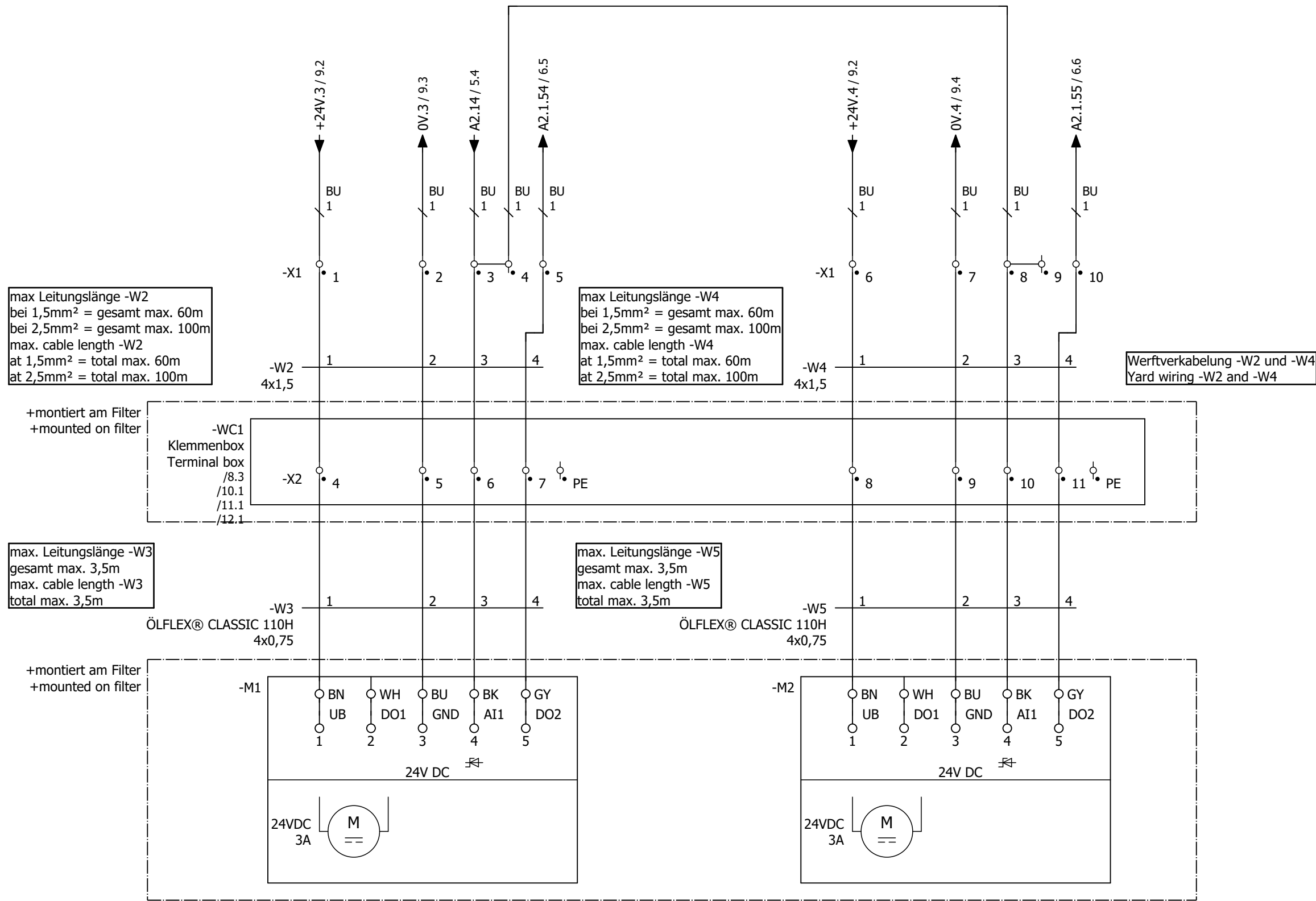

max Leitungslänge -W2
bei 1,5mm² = gesamt max. 60m
bei 2,5mm² = gesamt max. 100m
max. cable length -W2
at 1,5mm² = total max. 60m
at 2,5mm² = total max. 100m

max Leitungslänge -W4
bei 1,5mm² = gesamt max. 60m
bei 2,5mm² = gesamt max. 100m
max. cable length -W4
at 1,5mm² = total max. 60m
at 2,5mm² = total max. 100m

Werftverkabelung -W2 und -W4
Yard wiring -W2 and -W4

max. Leitungslänge -W3
gesamt max. 3,5m
max. cable length -W3
total max. 3,5m

max. Leitungslänge -W5
gesamt max. 3,5m
max. cable length -W5
total max. 3,5m

Getriebemotor 1
Gear motor 1

Getriebemotor 2
Gear motor 2

Alle nicht bezeichneten
Leitungen = 1mm²
All unnamed leads = 1mm²

REV04	Göricke	06.12.2024	Datum Date	12.03.2024		Hersteller Manufacturer Boll & Kirch Filterbau GmbH	Getriebemotoren Gear motors Filtertyp 6.49 ME 2.0 DN200	BK-Artikel-Nr.: BK-Article-No.:	4301027	=
REV03	Göricke	15.10.2024	Bearbeiter Edited by	ogoeरिके				Zeichnungs-Nr.: Drawing-No.:	Z46859	+
REV02	Göricke	22.04.2024	Auftrag Order							Blatt Page
Revision Revision	Bearbeiter Edited by	Datum Date	Vorgang Process					von of	24	

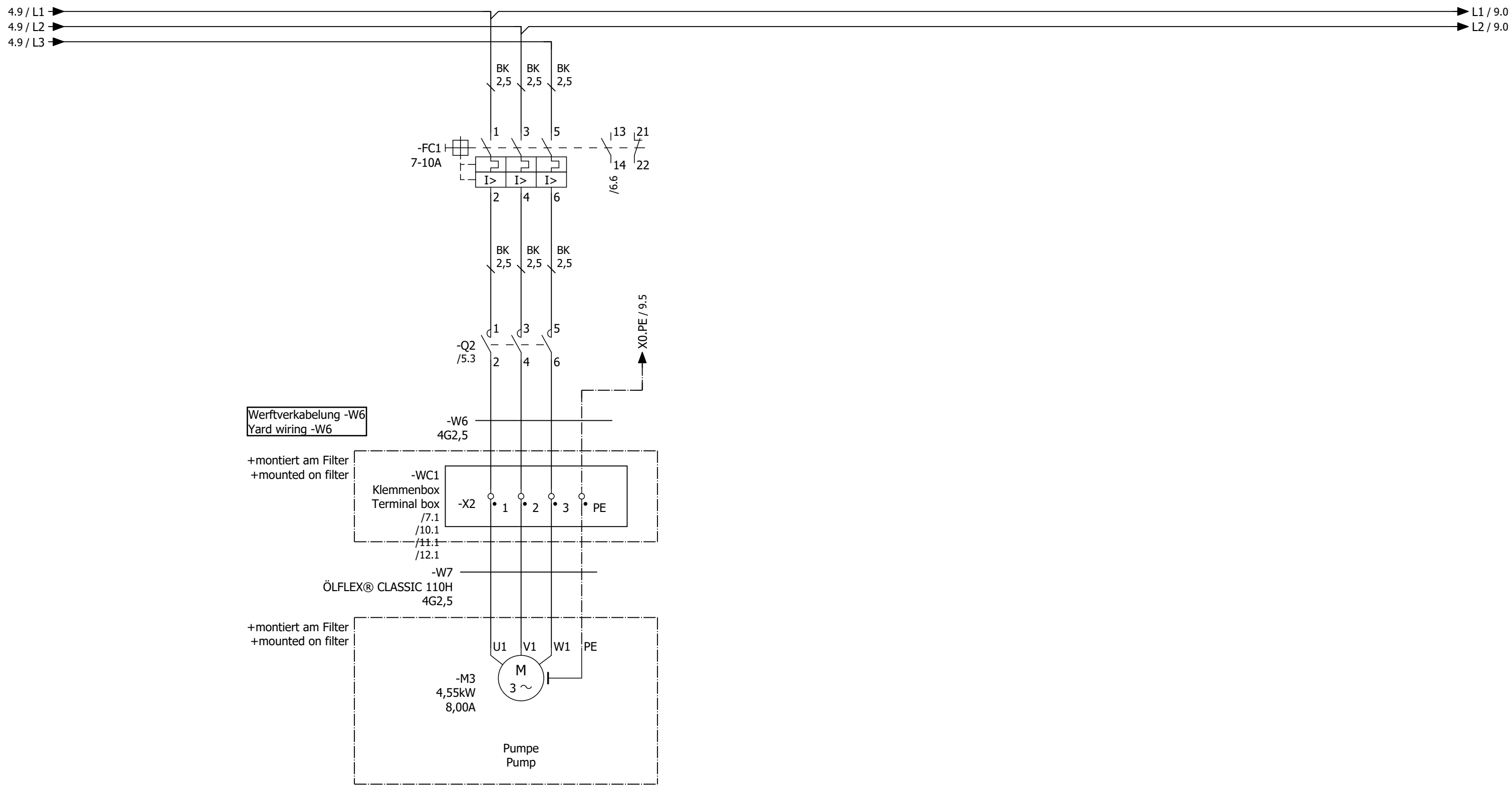

Alle nicht bezeichneten
 Leitungen = 1mm²
 All unnamed leads = 1mm²

REV04	Göricke	06.12.2024	Datum Date	12.03.2024		Hersteller Manufacturer Boll & Kirch Filterbau GmbH	Pumpe Gear motors Filtertyp 6.49 ME 2.0 DN200	BK-Artikel-Nr.: BK-Article-No.:	4301027	=
REV03	Göricke	15.10.2024	Bearbeiter Edited by	ogoeरिके				+ Blatt Page	8	
REV02	Göricke	22.04.2024	Auftrag Order					von of	24	
Revision Revision	Bearbeiter Edited by	Datum Date	Vorgang Process							
								Zeichnungs-Nr.: Drawing-No.:	Z46859	

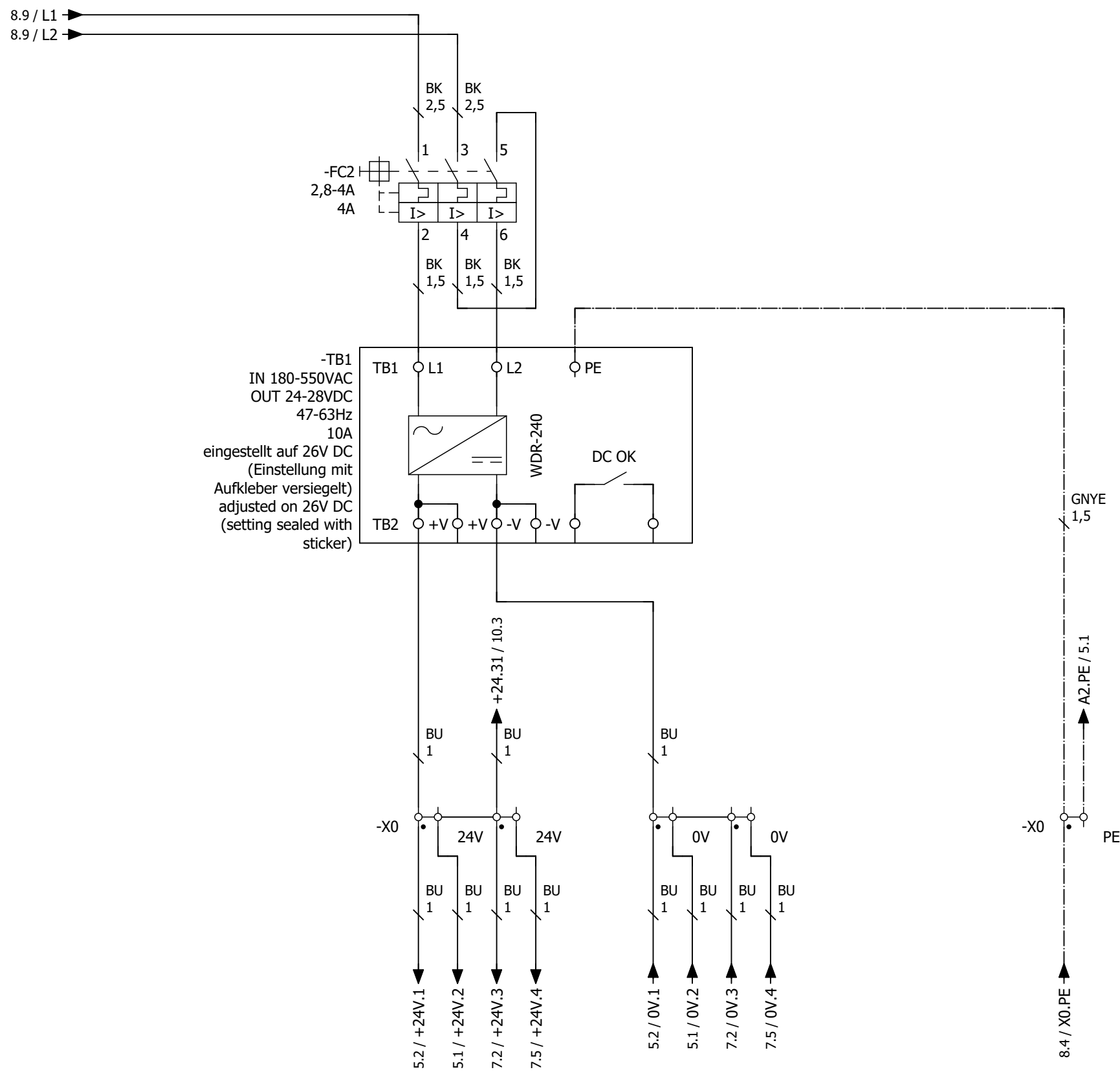

-TB1
IN 180-550VAC
OUT 24-28VDC
47-63Hz
10A
eingestellt auf 26V DC
(Einstellung mit
Aufkleber versiegelt)
adjusted on 26V DC
(setting sealed with
sticker)

Alle nicht bezeichneten
Leitungen = 1mm²
All unnamed leads = 1mm²

REV04	Göricke	06.12.2024	Datum Date	12.03.2024		Hersteller Manufacturer Boll & Kirch Filterbau GmbH	Netzteil Gear motors Filtertyp 6.49 ME 2.0 DN200	BK-Artikel-Nr.: BK-Article-No.:	4301027	=
REV03	Göricke	15.10.2024	Bearbeiter Edited by	ogoeरिकe				+ Blatt Page	9	
REV02	Göricke	22.04.2024	Auftrag Order					von of	24	
Revision Revision	Bearbeiter Edited by	Datum Date	Vorgang Process							
								Zeichnungs-Nr.: Drawing-No.:	Z46859	

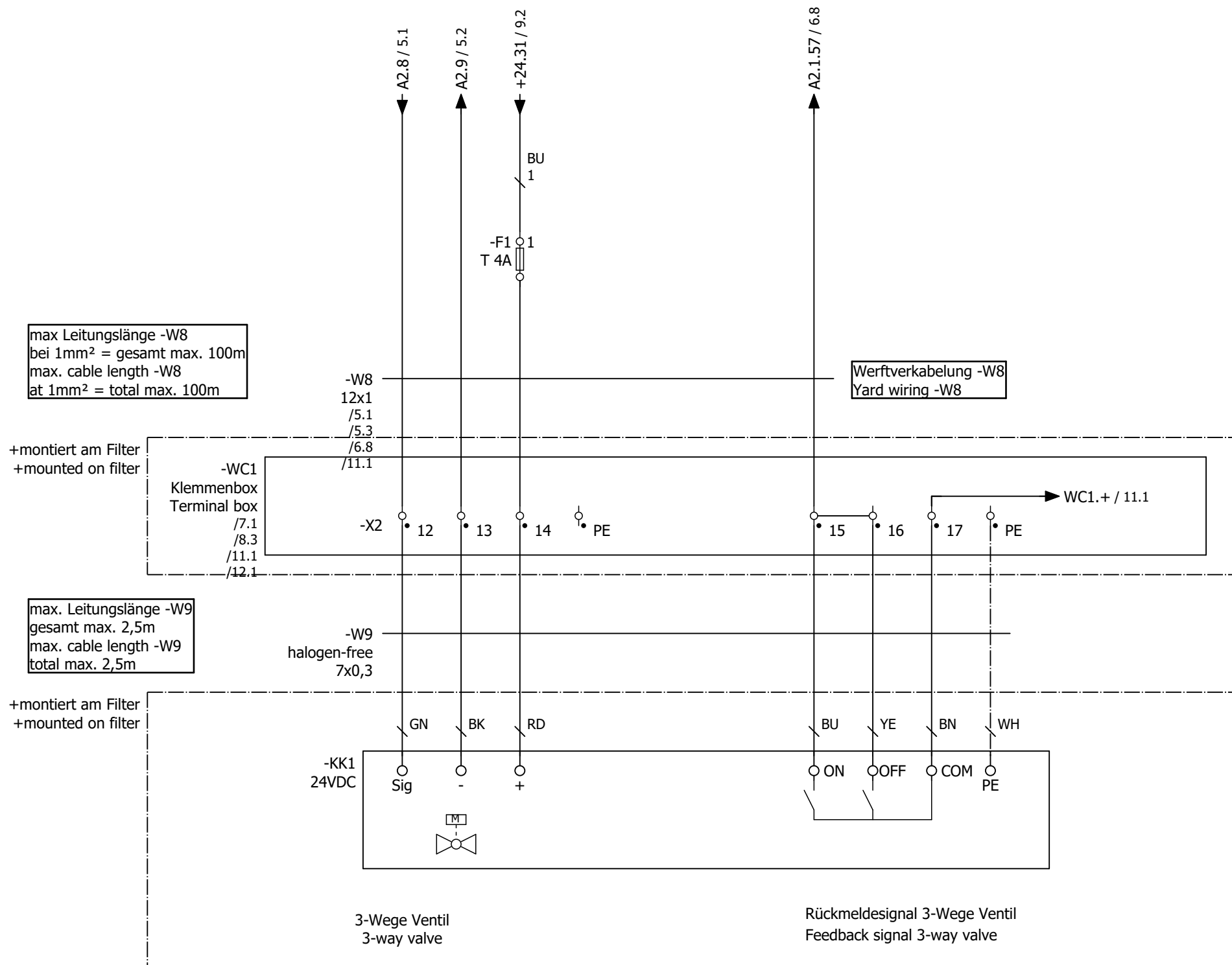

REV04	Göricke	06.12.2024	Datum Date	12.03.2024		Hersteller Manufacturer Boll & Kirch Filterbau GmbH	Ventil Valve Filtertyp 6.49 ME 2.0 DN200	BK-Artikel-Nr.: BK-Article-No.:	4301027	=	
REV03	Göricke	15.10.2024	Bearbeiter Edited by	ogoeरिके				+ Blatt Page	10		
REV02	Göricke	22.04.2024	Auftrag Order					Zeichnungs-Nr.: Drawing-No.:	Z46859	von of	24
Revision Revision	Bearbeiter Edited by	Datum Date	Vorgang Process								

max Leitungslänge -W8
bei 1mm² = gesamt max. 100m
max. cable length -W8
at 1mm² = total max. 100m

Wertverkabelung -W8
Yard wiring -W8

+montiert am Filter
+mounted on filter

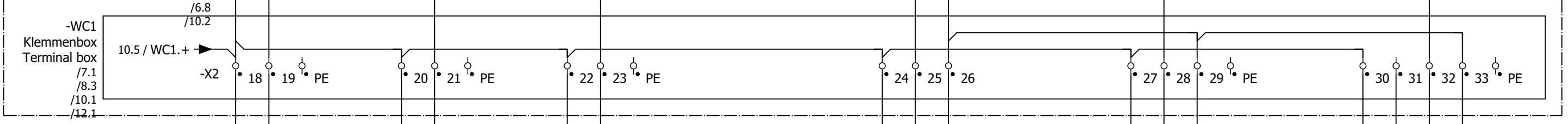

+montiert am Filter
+mounted on filter

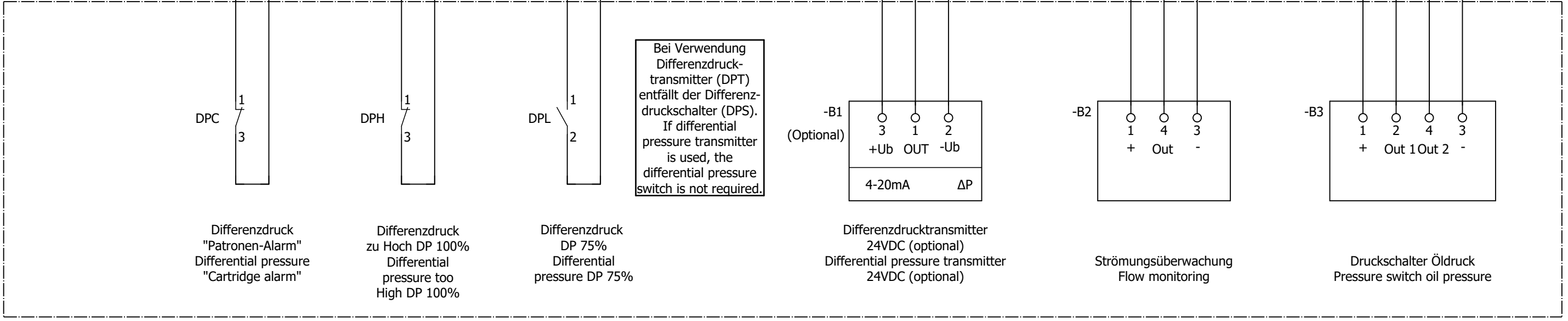

Bei Verwendung
Differenzdruck-
transmitter (DPT)
entfällt der Differenz-
druckschalter (DPS).
If differential
pressure transmitter
is used, the
differential pressure
switch is not required.

Alle nicht bezeichneten
Leitungen = 1mm²
All unnamed leads = 1mm²

REV04	Göricke	06.12.2024	Datum Date	12.03.2024		Hersteller Manufacturer Boll & Kirch Filterbau GmbH	Sensoren Sensors Filtertyp 6.49 ME 2.0 DN200	BK-Artikel-Nr.: BK-Article-No.:	4301027	=		
REV03	Göricke	15.10.2024	Bearbeiter Edited by	ogoeरिके							+	
REV02	Göricke	22.04.2024	Auftrag Order								Blatt Page	11
Revision Revision	Bearbeiter Edited by	Datum Date	Vorgang Process								Zeichnungs-Nr.: Drawing-No.:	Z46859

+montiert am Filter
+mounted on filter

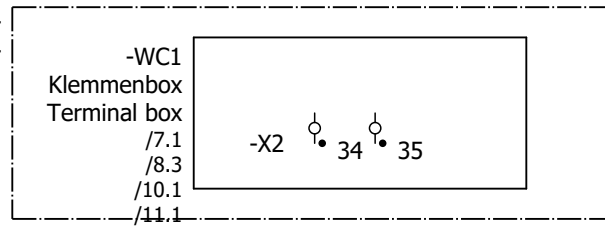

Reserve
Spare

Alle nicht bezeichneten
Leitungen = 1mm²
All unnamed leads = 1mm²

REV04	Göricke	06.12.2024	Datum Date	12.03.2024		Hersteller Manufacturer Boll & Kirch Filterbau GmbH	Reserve Spare Filtertyp 6.49 ME 2.0 DN200	BK-Artikel-Nr.: BK-Article-No.:	4301027	=
REV03	Göricke	15.10.2024	Bearbeiter Edited by	ogoericke				+ Blatt Page	12	
REV02	Göricke	22.04.2024	Auftrag Order					von of	24	
Revision Revision	Bearbeiter Edited by	Datum Date	Vorgang Process							
							Zeichnungs-Nr.: Drawing-No.:	Z46859		

Unterseite
Bottom side

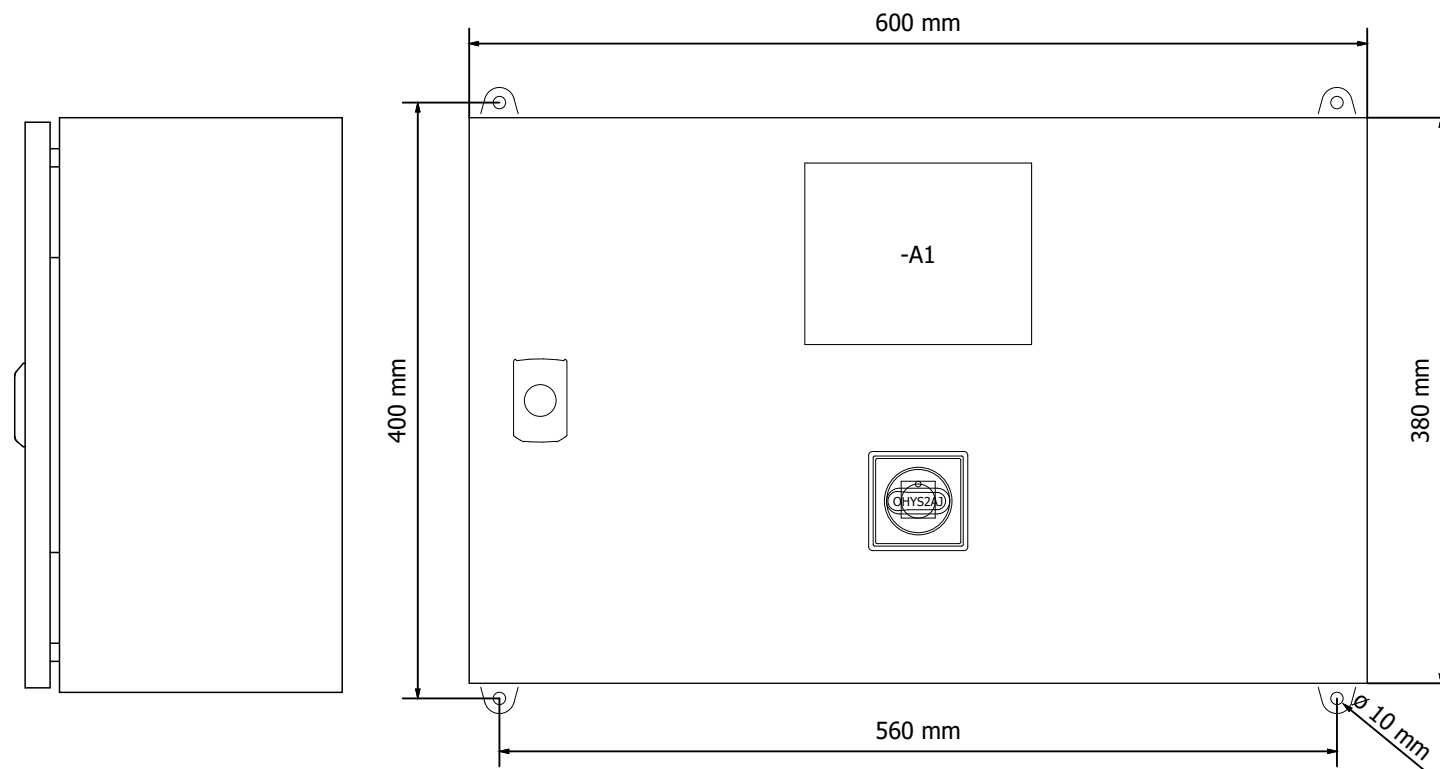
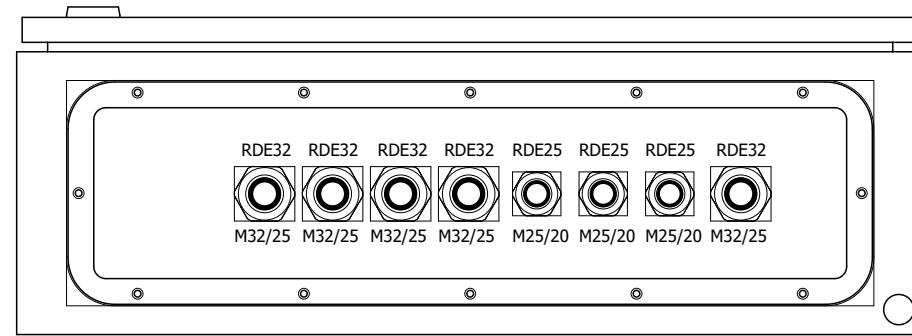

Oberseite
Topside

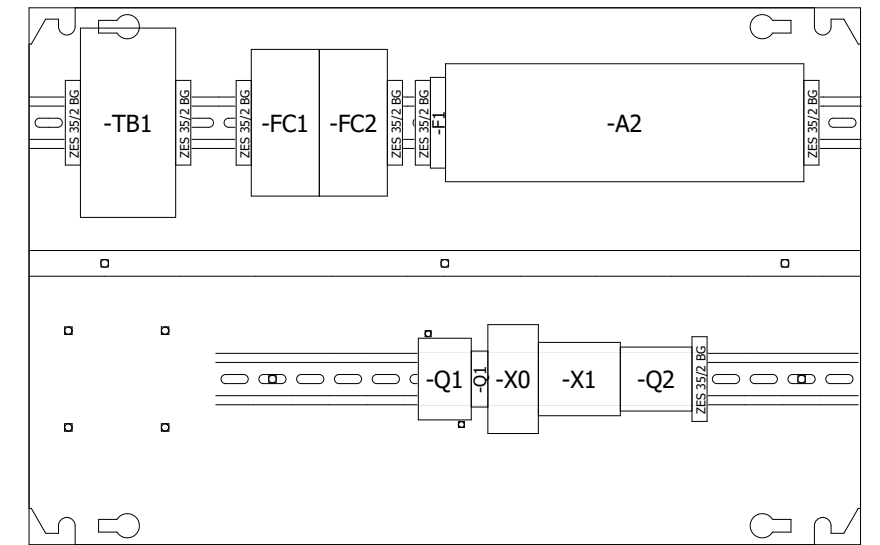
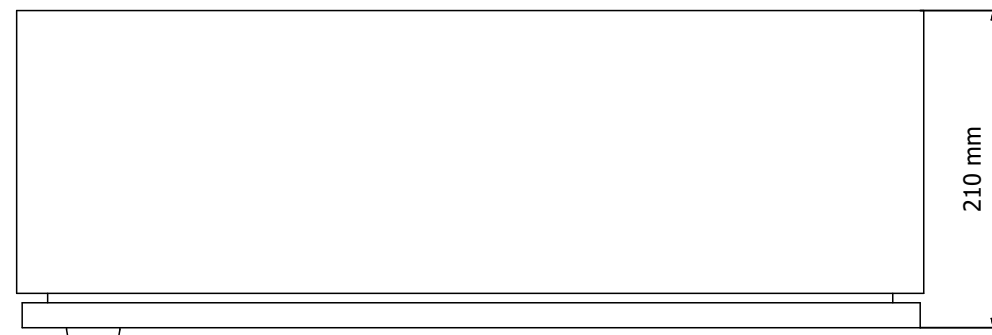

Reserve Sicherungssatz (bestehend aus: -A2-F1 / -A2-F1 / -F1)
Reserve fuse set (consisting of: -A2-F1 / -A2-F2 / -F1)
B&K ID 4301082

REV04	Göricke	06.12.2024	Datum Date	12.03.2024		Hersteller Manufacturer	Aufbauplan Assembling diagram	BK-Artikel-Nr.: BK-Article-No.:	4301027	=	
REV03	Göricke	15.10.2024	Bearbeiter Edited by	ogoeरिके		Boll & Kirch Filterbau GmbH	Filtertyp 6.49 ME 2.0 DN200	Zeichnungs-Nr.: Drawing-No.:	Z46859	+	
REV02	Göricke	22.04.2024	Auftrag Order							Blatt Page	13
Revision Revision	Bearbeiter Edited by	Datum Date	Vorgang Process							von of	24

- 1 Kabelverschraubung 1 für Pumpe -M3
EMSKV20 + RDE20 (Wiska)
Cable gland 1 for pump -M3
EMSKV20 + RDE20 (Wiska)
- 2 Kabelverschraubung 2 für 3-Wege-Kugelventil -KK1
EMSKV20 + RDE20 (Wiska)
Cable gland 2 for 3-way ball valve -KK1
EMSKV20 + RDE20 (Wiska)
- 3 Kabelverschraubung 3 für -B2 und -B3
EMSKV20 + MFD 20/02/050 (Wiska)
Cable gland 3 for -B2 and -B3
EMSKV20 + MFD 20/02/050 (Wiska)
- 4 Kabelverschraubung 4 für -M1 und -M2
EMSKV25 + MFD 25/02/070 (Wiska)
Cable gland 4 for -M1 and -M2
EMSKV25 + MFD 25/02/070 (Wiska)
- 5 Kabelverschraubung 5 für DPC + DPH + DPL
EMSKV25 + MFD 25/03/070 (Wiska)
Cable gland 5 for DPC + DPH + DPL
EMSKV25 + MFD 25/03/070 (Wiska)

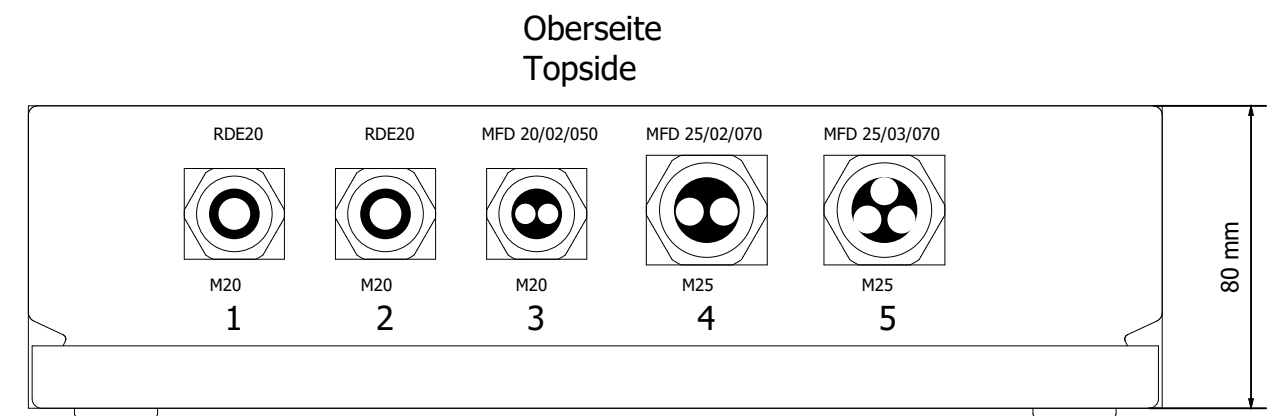
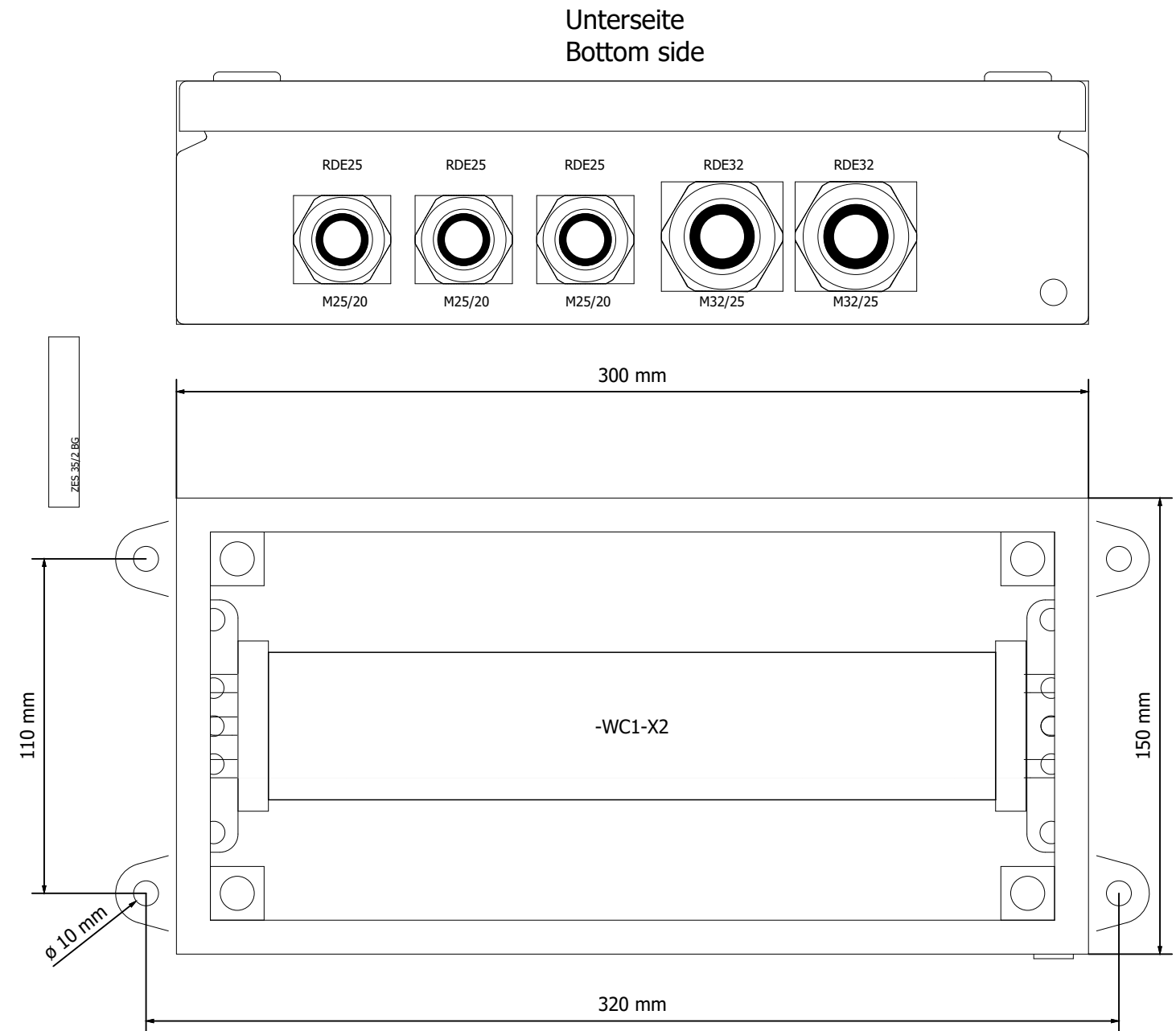

separater Klemmenkasten
Separate terminal box

B&K ID 4301033

Anschluß zu den elektrischen Bauteilen am Filter 6.49 ME
Connection to the electrical components on the filter 6.49 ME

REV04	Göricke	06.12.2024	Datum Date	12.03.2024		Hersteller Manufacturer	Aufbauplan Klemmenbox Assembling diagram	BK-Artikel-Nr.: BK-Article-No.:	4301027	=	
REV03	Göricke	15.10.2024	Bearbeiter Edited by	ogoericke		Boll & Kirch Filterbau GmbH	Filtertyp 6.49 ME 2.0 DN200	Zeichnungs-Nr.: Drawing-No.:	Z46859	+	
REV02	Göricke	22.04.2024	Auftrag Order							Blatt Page	14
Revision Revision	Bearbeiter Edited by	Datum Date	Vorgang Process							von of	24

Materialliste

Part list

Nr. No.	BMK DT	Anzahl Quant.	Bezeichnung Designation	Hersteller Manufacturer	Typ Type	Beschreibung Description	BK-Artikel-Nr.: BK-Article-No.:
1	-A1	1	Display	BOLL & KIRCH	BK2300	2 zeiliges universelles Display 2 lined universal Display	
2	-A1	1	Patchkabel Patch cable	Reco	SFTP	1m, RJ 45	4100403
3	-A2	1	E/A-Modul + iBoll I/O-Modul + iBoll	BOLL & KIRCH	BK2300+iBoll	ME 6.49 V2.0	4301028
4	-A2-F1	1	Schmelzsicherung Safety fuse	ESKA	522.516	0,8A, 5x20mm, Träge 0,8A, 5x20mm, Passive	4200162
5	-A2-F2	1	Schmelzsicherung Safety fuse	ESKA	522.520	2A, 5x20mm, Träge 2A, 5x20mm, Passive	4200163
6	-F1	1	Sicherungsklemme Fused terminal	Conta-Clip	SIK 10/Z BG	10 mm ² , NS35, Beige, Schraubanschluss 10 mm ² , NS35, Fawn, Screw terminal	4200526
7	-F1	2	Schmelzsicherung Safety fuse	ESKA	632.723	4 A, 6,3 x 32mm, Träge, 500/250 V 4 A, 6,3 x 32mm, Passive, 500/250 V	4200816
8	-FC1	1	Leistungsschalter Power circuit breaker	Siemens	3RV2011-1JA10	7-10A, BGR. S00, CLASS10, Schraubanschluss 7-10A, BGR. S00, CLASS10, Screw terminal	4200778
9	-FC1	1	Hilfsschalter Auxiliary switch	Siemens	3RV2901-1E	1NC+1NO, querliegend, für BGR. S00 / S0, Schraubanschluss 1NC+1NO, transversely, for BGR. S00 / S0, Screw terminal	4100257
10	-FC2	1	Leistungsschalter Power circuit breaker	Siemens	3RV2011-1EA10	2,8-4A, BGR. S00, CLASS 10, Schraubanschluss 2,8-4A, BGR. S00, CLASS 10, Screw terminal	4200473
11	-Q1	1	Lasttrennschalter Load interrupter	ABB	OT16F3	3 Polig, 16A, Bodenbefestigung 3 Pole, 16A, Bottom mounting	4200866
12	-Q1	1	Hilfskontakt Auxiliary contact	ABB	OA1G10	16A, 1NO, seitlich, für OT16...OT125 Hauptschalter 16A, 1NO, side mounting, for OT16...OT125 Main switch	4200617
13	-Q1	1	Hauptschaltergriff Main switch handle	ABB	OHYS2AJ	Rot/Gelb, IP65, NEMA 1 Red/Yellow, IP65, NEMA 1	4200866
14	-Q1	1	Hauptschalterwelle Main switch shaft	ABB	OXS6X180	180mm	4200866
15	-Q2	1	Leistungsschutz Power contactor	ABB	B7D-30-10-01	5,5kW, 1NO, 24VDC, Schraubanschluss, mit Diode 5,5kW, 1NO, 24VDC, Screw terminal, with Diode	4200867
16	-TB1	1	Netzteil Power supply unit	Mean Well	WDR-240-24	IN 180-550VAC, 2 phasig, 47-63Hz, OUT 24-29VDC, 10A, 240W, UL508 IN 180-550VAC, 2 phase, 47-63Hz, OUT 24-29VDC, 10A, 240W, UL508	4200864
17	-U1	1	Wandschrank Wall cabinet	Rittal	AX 1039.199 Y289549	600 x 380 x 210mm, Stahl, RAL7035, bearbeitet 600 x 380 x 210mm, Steel, RAL7035, edited	4301094
18	-U1	1	Wandbefestigungshalter Wall mounting bracket	Rittal	KX 1590.010	10 mm, für AX und KX, Stahl 10 mm, for AX and KX, Steel	4300840
19	-U1	5	Kabelverschraubung Cable gland	WISKA	EMSKV 25-32 EMV-Z	M25, Messing, vernickelt, EMV-fest, Kabeldurchmesser 13-21mm M25, Brass, nickel-plated, EMC-proof, Cable diameter 13-21mm	4100098
20	-U1	5	Gegenmutter Locknut	WISKA	EMMU 25	M25, Messing, vernickelt M25, Brass, nickel-plated	4100310

REV04	Göricke	06.12.2024	Datum Date	12.03.2024		Hersteller Manufacturer Boll & Kirch Filterbau GmbH	Materialliste Part list Filtertyp 6.49 ME 2.0 DN200	BK-Artikel-Nr.: BK-Article-No.:	4301027	=
REV03	Göricke	15.10.2024	Bearbeiter Edited by	ogoeरिके				Zeichnungs-Nr.: Drawing-No.:	Z46859	+
REV02	Göricke	22.04.2024	Auftrag Order							Blatt Page
Revision Revision	Bearbeiter Edited by	Datum Date	Vorgang Process					von of	24	

Materialliste

Part list

Nr. No.	BMK DT	Anzahl Quant.	Bezeichnung Designation	Hersteller Manufacturer	Typ Type	Beschreibung Description	BK-Artikel-Nr.: BK-Article-No.:
21	-U1	5	Reduzierdichteinsatz Reduced seal insert	WISKA	RDE 32	Kabeldurchmesser 9-14mm, für M32 Kabelverschraubung Cable diameter 9-14mm, for M32 Cable gland	3250002
22	-U1	3	Kabelverschraubung Cable gland	WISKA	EMSKV 20-25 EMV-Z	M20, Messing, vernickelt, EMV-fest, Kabeldurchmesser 9-17mm M20, Brass, nickel-plated, EMC-proof, Cable diameter 9-17mm	4100097
23	-U1	3	Gegenmutter Locknut	WISKA	EMMU 20	M20, Messing, vernickelt M20, Brass, nickel-plated	4100309
24	-U1	3	Reduzierdichteinsatz Reduced seal insert	WISKA	RDE 25	Kabeldurchmesser 7-12mm, für M25 Kabelverschraubung Cable diameter 7-12mm, for M25 Cable gland	3250001
25	-U1	7	Endwinkel End angle	Conta-Clip	ZES 35/2 BG	Beige, für NS35 Tragschiene Fawn, for NS35 Mounting rail	4100311
26	-WC1-U2	1	Klemmenkasten Terminal box	Rittal	KX 1515.199 Y289548	300 x 150 x 80mm, Lackiert, RAL7035, IP65, bearbeitet 300 x 150 x 80mm, Lacquered, RAL7035, IP65, edited	4301095
27	-WC1-U2	1	Wandbefestigungshalter Wall mounting bracket	Rittal	KX 1590.010	10 mm, für AX und KX, Stahl 10 mm, for AX and KX, Steel	4300840
28	-WC1-U2	2	Kabelverschraubung Cable gland	WISKA	EMSKV 25-32 EMV-Z	M25, Messing, vernickelt, EMV-fest, Kabeldurchmesser 13-21mm M25, Brass, nickel-plated, EMC-proof, Cable diameter 13-21mm	4100098
29	-WC1-U2	3	Kabelverschraubung Cable gland	WISKA	EMSKV 20-25 EMV-Z	M20, Messing, vernickelt, EMV-fest, Kabeldurchmesser 9-17mm M20, Brass, nickel-plated, EMC-proof, Cable diameter 9-17mm	4100097
30	-WC1-U2	2	Kabelverschraubung Cable gland	WISKA	EMSKV 25	M25, Messing, vernickelt, GL UL M25, Brass, nickel-plated, GL UL	4100435
31	-WC1-U2	3	Kabelverschraubung Cable gland	WISKA	EMSKV 20	M20, Messing, vernickelt, GL UL M20, Brass, nickel-plated, GL UL	4100237
32	-WC1-U2	4	Gegenmutter Locknut	WISKA	EMMU 25	M25, Messing, vernickelt M25, Brass, nickel-plated	4100310
33	-WC1-U2	6	Gegenmutter Locknut	WISKA	EMMU 20	M20, Messing, vernickelt M20, Brass, nickel-plated	4100309
34	-WC1-U2	2	Reduzierdichteinsatz Reduced seal insert	WISKA	RDE 32	Kabeldurchmesser 9-14mm, für M32 Kabelverschraubung Cable diameter 9-14mm, for M32 Cable gland	3250002
35	-WC1-U2	3	Reduzierdichteinsatz Reduced seal insert	WISKA	RDE 25	Kabeldurchmesser 7-12mm, für M25 Kabelverschraubung Cable diameter 7-12mm, for M25 Cable gland	3250001
36	-WC1-U2	2	Reduzierdichteinsatz Reduced seal insert	WISKA	RDE 20	Kabeldurchmesser 4-8mm, für M20 Kabelverschraubung Cable diameter 4-8mm, for M20 Cable gland	3290017
37	-WC1-U2	1	Mehrfachdichteinsatz Multiple density insert	WISKA	MFD 20/02/050	für M20, 2 x 5mm for M20, 2 x 5mm	3250029
38	-WC1-U2	1	Mehrfachdichteinsatz Multiple density insert	WISKA	MFD 25/02/070	für M25, 2 x 7mm for M25, 2 x 7mm	3250028
39	-WC1-U2	1	Mehrfachdichteinsatz Multiple density insert	WISKA	MFD 25/03/070	für M25, 3 x 7mm for M25, 3 x 7mm	3250017
40	-WC1-U2	2	Endwinkel End angle	Conta-Clip	ZES 35/2 BG	Beige, für NS35 Tragschiene Fawn, for NS35 Mounting rail	4100311

REV04	Göricke	06.12.2024	Datum Date	12.03.2024		Hersteller Manufacturer Boll & Kirch Filterbau GmbH	Materialliste Part list Filtertyp 6.49 ME 2.0 DN200	BK-Artikel-Nr.: BK-Article-No.:	4301027	=
REV03	Göricke	15.10.2024	Bearbeiter Edited by	ogoeरिके				Zeichnungs-Nr.: Drawing-No.:	Z46859	+
REV02	Göricke	22.04.2024	Auftrag Order							Blatt Page
Revision Revision	Bearbeiter Edited by	Datum Date	Vorgang Process					von of	24	

Materialliste

Part list

Nr. No.	BMK DT	Anzahl Quant.	Bezeichnung Designation	Hersteller Manufacturer	Typ Type	Beschreibung Description	BK-Artikel-Nr.: BK-Article-No.:
41	-WC1-X2	35	Durchgangsklemme Feed-through terminal block	Phoenix Contact	ST 2,5	2,5 mm ² , NS35, Grau, Zugfederanschluss 2,5 mm ² , NS35, Gray, Cage clamp connection	4100547
42	-WC1-X2	10	Schutzleiterklemme Protective conductor terminal	Phoenix Contact	ST 2,5-PE	4 mm ² , NS35, Grün/Gelb, Zugfederanschluss 4 mm ² , NS35, Green/Yellow, Cage clamp connection	4100548
43	-WC1-X2	2	Steckbrücke Plug-in bridge	Phoenix Contact	FBS 10-5	10er, 2,5mm ² Klemmen 10er, 2,5mm ² Terminals	4100558
44	-WC1-X2	1	Steckbrücke Plug-in bridge	Phoenix Contact	FBS 2-5	2er, für 2,5mm ² Klemmen 2er, for 2,5mm ² Terminals	4100554
45	-WC1-X2	1	Steckbrücke Plug-in bridge	Phoenix Contact	FBS 20-5	20er, für 2,5mm ² Klemmen 20er, for 2,5mm ² Terminals	4100559
46	-WC1-X2	1	Abschlussdeckel End cover	Phoenix Contact	D-ST 2,5	Grau, ST 2,5 Klemme Gray, ST 2,5 Terminal	4100119
47	-X0	2	Schutzleiterklemme Protective conductor terminal	Phoenix Contact	ST 2,5-QUATTRO-PE	2,5mm ² , NS35, Grün/Gelb, Zugfederanschluss 2,5mm ² , NS35, Green/Yellow, Cage clamp connection	4100550
48	-X0	4	Durchgangsklemme Feed-through terminal block	Phoenix Contact	ST 2,5-QUATTRO	4mm ² , NS35, Grau, Zugfederanschluss 4mm ² , NS35, Gray, Cage clamp connection	4100549
49	-X0	2	Steckbrücke Plug-in bridge	Phoenix Contact	FBS 2-5	2er, für 2,5mm ² Klemmen 2er, for 2,5mm ² Terminals	4100554
50	-X0	1	Abschlussdeckel End cover	Phoenix Contact	D-ST 2,5-QUATTRO	Grau Gray	4100551
51	-X1	10	Durchgangsklemme Feed-through terminal block	Phoenix Contact	ST 2,5	2,5 mm ² , NS35, Grau, Zugfederanschluss 2,5 mm ² , NS35, Gray, Cage clamp connection	4100547
52	-X1	2	Steckbrücke Plug-in bridge	Phoenix Contact	FBS 2-5	2er, für 2,5mm ² Klemmen 2er, for 2,5mm ² Terminals	4100554
53	-X1	1	Abschlussdeckel End cover	Phoenix Contact	D-ST 2,5	Grau, ST 2,5 Klemme Gray, ST 2,5 Terminal	4100119

REV04	Göricke	06.12.2024	Datum Date	12.03.2024		Hersteller Manufacturer Boll & Kirch Filterbau GmbH	Materialliste Part list Filtertyp 6.49 ME 2.0 DN200	BK-Artikel-Nr.: BK-Article-No.:	4301027	=	
REV03	Göricke	15.10.2024	Bearbeiter Edited by	ogoeरिके				+ Blatt Page	17		
REV02	Göricke	22.04.2024	Auftrag Order					Zeichnungs-Nr.: Drawing-No.:	Z46859	von of	24
Revision Revision	Bearbeiter Edited by	Datum Date	Vorgang Process								

Klemmenplan Terminal diagram

Funktionstext Function text	Kabeltyp Cable type	Kabelname Cable name	-W8	= + #-F1						
				Zielbezeichnung Target designation		Zielbezeichnung Target designation		Blatt Page Pfad Path		
				Bezeichnung Designation	Anschluss Connection	Klemme Terminal	Brücke Jumper		Bezeichnung Designation	Anschluss Connection
3-Wege Ventil 3-way valve				-WC1-X2	14	1		-X0	24V	&1/10.3

REV04	Göricke	06.12.2024	Datum Date	12.03.2024		Hersteller Manufacturer	Klemmenplan Terminal diagram	BK-Artikel-Nr.: BK-Article-No.:	4301027	=	
REV03	Göricke	15.10.2024	Bearbeiter Edited by	ogoericke		Boll & Kirch Filterbau GmbH	Filtertyp 6.49 ME 2.0 DN200	Zeichnungs-Nr.: Drawing-No.:	Z46859	+	
REV02	Göricke	22.04.2024	Auftrag Order							Blatt Page	18
Revision Revision	Bearbeiter Edited by	Datum Date	Vorgang Process							von of	24

Klemmenplan Terminal diagram

Funktionstext Function text	Kabelname Cable name	Kabeltyp Cable type	-W5	-W3	-W7	=+#-WC1-X2					-W6	-W2	-W4		
			ÖLFLEX® CLASSI C 110H	ÖLFLEX® CLASSI C 110H	ÖLFLEX® CLASSI C 110H	Zielbezeichnung Target designation		Zielbezeichnung Target designation							
			Bezeichnung Designation	Anschluss Connection	Klemme Terminal	Brücke Jumper	Bezeichnung Designation	Anschluss Connection	Blatt Page Pfad Path						
Pumpe Pump						-M3	U1	1	·	-Q2	2	&1/8.3			
Pumpe Pump						-M3	V1	2	·	-Q2	4	&1/8.3			
Pumpe Pump						-M3	W1	3	·	-Q2	6	&1/8.3			
Pumpe Pump						-M3	PE	PE	·	-X0	PE	&1/8.3			
Getriebemotor 1 Gear motor 1				1		-M1	BN	4	·	-X1	1	&1/7.2	1		
Getriebemotor 1 Gear motor 1				2		-M1	BU	5	·	-X1	2	&1/7.2	2		
Getriebemotor 1 Gear motor 1				3		-M1	BK	6	·	-X1	3	&1/7.3	3		
Getriebemotor 1 Gear motor 1				4		-M1	GY	7	·	-X1	5	&1/7.3	4		
								PE	·			&1/7.3			
Getriebemotor 2 Gear motor 2			1			-M2	BN	8	·	-X1	6	&1/7.5		1	
Getriebemotor 2 Gear motor 2			2			-M2	BU	9	·	-X1	7	&1/7.5		2	
Getriebemotor 2 Gear motor 2			3			-M2	BK	10	·	-X1	8	&1/7.6		3	
Getriebemotor 2 Gear motor 2			4			-M2	GY	11	·	-X1	10	&1/7.6		4	
								PE	·			&1/7.6			

REV04	Göricke	06.12.2024	Datum Date	12.03.2024		Hersteller Manufacturer	Klemmenplan Terminal diagram	BK-Artikel-Nr.: BK-Article-No.:	4301027	=
REV03	Göricke	15.10.2024	Bearbeiter Edited by	ogoericke		Boll & Kirch Filterbau GmbH	Filtertyp 6.49 ME 2.0 DN200	Zeichnungs-Nr.: Drawing-No.:	Z46859	+
REV02	Göricke	22.04.2024	Auftrag Order							Blatt Page
Revision Revision	Bearbeiter Edited by	Datum Date	Vorgang Process					von of	24	

Klemmenplan Terminal diagram

Funktionstext Function text	Kabelname Cable name	Kabeltyp Cable type	-W12 ÖLFLEX® CLASSI C 110H	-W11 ÖLFLEX® CLASSI C 110H	-W9 halogen-free	=+#-WC1-X2						-W8
						Zielbezeichnung Target designation		Zielbezeichnung Target designation		Blatt Page Pfad Path		
						Bezeichnung Designation	Anschluss Connection	Klemme Terminal	Brücke Jumper		Bezeichnung Designation	
3-Wege Ventil 3-way valve					GN	-KK1	Sig	12	·	-A2	8	&1/10.2
3-Wege Ventil 3-way valve					BK	-KK1	-	13	·	-A2	9	&1/10.2
3-Wege Ventil 3-way valve					RD	-KK1	+	14	·	-F1	1	&1/10.3
3-Wege Ventil 3-way valve								PE	·			&1/10.3
3-Wege Ventil 3-way valve					BU	-KK1	ON	15		-A2.1	57	&1/10.4
3-Wege Ventil 3-way valve					YE	-KK1	OFF	16				&1/10.4
3-Wege Ventil 3-way valve					BN	-KK1	COM	17	·			&1/10.5
3-Wege Ventil 3-way valve					WH	-KK1	PE	PE	·			&1/10.5
Differenzdruck "Patronen-Alarm" Differential pressure "Cartridge alarm"							1	18	·	-A2	39	&1/11.2
Differenzdruck "Patronen-Alarm" Differential pressure "Cartridge alarm"							3	19	·	-A2	32	&1/11.2
Differenzdruck "Patronen-Alarm" Differential pressure "Cartridge alarm"								PE	·			&1/11.2
Differenzdruck "Patronen-Alarm" Differential pressure "Cartridge alarm"							1	20	·	-A2	39	&1/11.2
Differenzdruck zu Hoch DP 100% Differential pressure too High DP 100%							3	21	·	-A2	38	&1/11.3
Differenzdruck zu Hoch DP 100% Differential pressure too High DP 100%								PE	·			&1/11.3

REV04	Göricke	06.12.2024	Datum Date	12.03.2024		Hersteller Manufacturer	Klemmenplan Terminal diagram	BK-Artikel-Nr.: BK-Article-No.:	4301027	=
REV03	Göricke	15.10.2024	Bearbeiter Edited by	ogoericke		Boll & Kirch Filterbau GmbH	Filtertyp 6.49 ME 2.0 DN200	Zeichnungs-Nr.: Drawing-No.:	Z46859	+
REV02	Göricke	22.04.2024	Auftrag Order							Blatt Page
Revision Revision	Bearbeiter Edited by	Datum Date	Vorgang Process					von of	24	

Klemmenplan Terminal diagram

Funktionstext Function text	Kabelname Cable name	-W15	-W14	-W13	=+#-WC1-X2						-W8				
	Kabeltyp Cable type				Zielbezeichnung Target designation		Zielbezeichnung Target designation		Blatt Page Pfad Path						
	EVC187, M12, PU R, halogen-free				EVC187, M12, PU R, halogen-free	ÖLFLEX® CLASSI C 110H	Bezeichnung Designation	Anschluss Connection		Klemme Terminal		Brücke Jumper	Bezeichnung Designation	Anschluss Connection	
Differenzdruck zu Hoch DP 100% Differential pressure too High DP 100%						1	22	•	•			&1/11.3			
Differenzdruck DP 75% Differential pressure DP 75%						2	23	•	•			-A2	40	&1/11.4	
Differenzdruck DP 75% Differential pressure DP 75%							PE	•	•					&1/11.4	
Differenzdrucktransmitter 24VDC (optional) Differential pressure transmitter 24VDC (optional)					-B1	3	24	•	•					&1/11.5	
Differenzdrucktransmitter 24VDC (optional) Differential pressure transmitter 24VDC (optional)					-B1	1	25	•	•			-A2	41	&1/11.5	
Differenzdrucktransmitter 24VDC (optional) Differential pressure transmitter 24VDC (optional)					-B1	2	26	•	•			-A2	42	&1/11.6	
Strömungsüberwachung Flow monitoring			BN		-B2	1	27	•	•					&1/11.7	
Strömungsüberwachung Flow monitoring			BK		-B2	4	28	•	•			-A2	36	&1/11.7	
Strömungsüberwachung Flow monitoring			BU		-B2	3	29	•	•					&1/11.7	
Strömungsüberwachung Flow monitoring							PE	•	•					&1/11.7	
Druckschalter Öldruck Pressure switch oil pressure		BN			-B3	1	30	•	•					&1/11.8	
Druckschalter Öldruck Pressure switch oil pressure		WH			-B3	2	31	•	•					&1/11.8	
Druckschalter Öldruck Pressure switch oil pressure		BK			-B3	4	32	•	•			-A2	34	&1/11.8	
Druckschalter Öldruck Pressure switch oil pressure		BU			-B3	3	33	•	•					&1/11.9	

REV04	Göricke	06.12.2024	Datum Date	12.03.2024		Hersteller Manufacturer Boll & Kirch Filterbau GmbH	Klemmenplan Terminal diagram Filtertyp 6.49 ME 2.0 DN200	BK-Artikel-Nr.: 4301027	=	
REV03	Göricke	15.10.2024	Bearbeiter Edited by	ogoericke				BK-Artikel-No.:		+
REV02	Göricke	22.04.2024	Auftrag Order					Zeichnungs-Nr.: Z46859	Blatt Page	21
Revision Revision	Bearbeiter Edited by	Datum Date	Vorgang Process					Drawing-No.:	von of	24

Klemmenplan Terminal diagram

Funktionstext Function text	Kabelname Cable name	=+#-WC1-X2									
	Kabeltyp Cable type	Zielbezeichnung Target designation					Zielbezeichnung Target designation				
		Bezeichnung Designation	Anschluss Connection	Klemme Terminal	Brücke Jumper	Bezeichnung Designation	Anschluss Connection	Blatt Page Pfad Path			
Druckschalter Öldruck Pressure switch oil pressure				PE	.						&1/11.9
Reserve Spare				34	.						&1/12.2
Reserve Spare				35	.						&1/12.2

REV04	Göricke	06.12.2024	Datum Date	12.03.2024		Hersteller Manufacturer	Klemmenplan Terminal diagram	BK-Artikel-Nr.: BK-Article-No.:	4301027	=
REV03	Göricke	15.10.2024	Bearbeiter Edited by	ogoericke		Boll & Kirch Filterbau GmbH	Filtertyp 6.49 ME 2.0 DN200	Zeichnungs-Nr.: Drawing-No.:	Z46859	+
REV02	Göricke	22.04.2024	Auftrag Order							Blatt Page
Revision Revision	Bearbeiter Edited by	Datum Date	Vorgang Process					von of	24	

Klemmenplan Terminal diagram

Funktionstext Function text	Kabelname Cable name	Kabeltyp Cable type	-W1	= + # -X0						
				Zielbezeichnung Target designation		Zielbezeichnung Target designation		Blatt Page Pfad Path		
				Bezeichnung Designation	Anschluss Connection	Klemme Terminal	Brücke Jumper		Bezeichnung Designation	Anschluss Connection
Einspeisung vom Netz Power supply input from mains			GNYE	-PE		PE	·	-U2	PE1	&1/4.1
				-A2;-A2	5;6	24V		-TB1	TB2:+V	&1/9.2
				-X1;-X1	1;6	24V		-F1	1	&1/9.2
				-A2;-A2	4;7	0V		-TB1	TB2:-V	&1/9.3
				-X1;-X1	2;7	0V				&1/9.3
				-WC1-X2;-A2	PE;3	PE	·	-TB1	TB1:PE	&1/9.5

REV04	Göricke	06.12.2024	Datum Date	12.03.2024		Hersteller Manufacturer	Klemmenplan Terminal diagram	BK-Artikel-Nr.: BK-Article-No.:	4301027	=
REV03	Göricke	15.10.2024	Bearbeiter Edited by	ogoericke		Boll & Kirch Filterbau GmbH	Filtertyp 6.49 ME 2.0 DN200	Zeichnungs-Nr.: Drawing-No.:	Z46859	+
REV02	Göricke	22.04.2024	Auftrag Order							Blatt Page
Revision Revision	Bearbeiter Edited by	Datum Date	Vorgang Process					von of	24	

Klemmenplan Terminal diagram

Funktionstext Function text	Kabelname Cable name	Kabeltyp Cable type	-W4	-W2	= + # -X1						
					Zielbezeichnung Target designation		Zielbezeichnung Target designation		Klemme Terminal	Brücke Jumper	Blatt Page Pfad Path
					Bezeichnung Designation	Anschluss Connection	Bezeichnung Designation	Anschluss Connection			
Getriebemotor 1 Gear motor				1	-WC1-X2	4	1	·	-X0	24V	&1/7.2
Getriebemotor 1 Gear motor				2	-WC1-X2	5	2	·	-X0	0V	&1/7.2
Getriebemotor 1 Gear motor				3	-WC1-X2	6	3		-A2	14	&1/7.3
Getriebemotor 1 Gear motor 1							4		&1/7.3		
Getriebemotor 1 Gear motor				4	-WC1-X2	7	5	·	-A2.1	54	&1/7.3
Getriebemotor 2 Gear motor			1		-WC1-X2	8	6	·	-X0	24V	&1/7.5
Getriebemotor 2 Gear motor			2		-WC1-X2	9	7	·	-X0	0V	&1/7.5
Getriebemotor 2 Gear motor			3		-WC1-X2	10	8				&1/7.6
Getriebemotor 2 Gear motor 2							9		&1/7.6		
Getriebemotor 2 Gear motor			4		-WC1-X2	11	10	·	-A2.1	55	&1/7.6

REV04	Göricke	06.12.2024	Datum Date	12.03.2024		Hersteller Manufacturer	Klemmenplan Terminal diagram	BK-Artikel-Nr.: BK-Article-No.:	4301027	=
REV03	Göricke	15.10.2024	Bearbeiter Edited by	ogoericke		Boll & Kirch Filterbau GmbH	Filtertyp 6.49 ME 2.0 DN200	Zeichnungs-Nr.: Drawing-No.:	Z46859	+
REV02	Göricke	22.04.2024	Auftrag Order							Blatt Page
Revision Revision	Bearbeiter Edited by	Datum Date	Vorgang Process			von of	24			