



EPLAN P8

Elektrodokumentation Electrical documentation

Hersteller:
Manufacturer: Boll & Kirch Filterbau GmbH
Siemensstraße 10-14
D-50170 Kerpen

Algemeine Daten:
General informations:

BK-Artikel-Nr.: 4301025
BK-Article-No.:

Projektdatei:
Project data:

Zeichnungs-Nr.: Z46857
Drawing-No.:

Typ: Filtertyp 6.49 ME 2.0 DN65-DN100
Type:

Bezeichnung: Vollautomatischer Rückspülfilter
Designation: Fully automatic back flushing filter

Anzahl Seiten: 24
Number of pages:

Bearbeiter: ogoericke
Edited by:

Datum: 22.02.2024
Date:

Normen:
Specifications: Ausführung der Schaltanlage nach DIN EN 61439-5:2015-10. Bestimmungen für fabrikfertige Schaltgerätekombinationen mit Nennspannung bis 750V. Nennisolationsspannung 450/750V und Nennspannung 450/750V.
Execution of the switchgear according to DIN EN 61439-5:2015-10. Regulations for factory-fabricated switchgear combinations with rated voltage up to 750V. Rated insulation voltage 450/750V and rated voltage 450/750V.

Technische Kenngrößen
Technical characteristics

Gehäuse:
Enclosure:

Bezeichnung: AX 1039.000
Designation:

Materialtyp: Stahlblech
Material: Carbon steel

Abmessungen: 600 x 380 x 210mm
Dimensionings:

Schutzart: IP65
Degree protection:

Farbe: RAL7035
Color:

Türanschlag: Rechts
Door stop: Right

Montage: Wandabstandshalter
Mounting: Wall spacer

Gewicht: 18,5kg+3,4kg(Box)
Weight:

Leitungsfarben:
Wire colors:

Arbeitsstromkreis: Schwarz
Load circuit: Black

Schutzleiter: Grün/Gelb
Protection conductor: Green/Yellow

Steuerstromkreis: Rot
Control circuit: Red

Fremdspannung: Orange
External voltage: Orange

Verdrahtung
Wiring

Hauptstromkreis wird mit 1,5mm² und Steuerstromkreis mit 1mm² verlegt.
Die Verdrahtung erfolgt von oben nach unten bzw. von links nach rechts gemäß den Stromlaufplänen.
The main circuit is laid with 1.5mm² and the control circuit with 1mm².
The wiring is carried out from top to bottom or from left to right according to the circuit diagrams.

Spannungen:
Voltages:

Betriebsspannung: 3~/PE
Operating voltage: 440V

Frequenz: 60Hz
Frequency:

Steuerspannung: 24V DC
Control voltage:

Sonstiges:
Miscellaneous:

Aderbeschriftung: -
Wire labeling:

Kabeltyp: H07V-K
Cable type:

Netzform: IT
Network types:

Umgebungstemperatur: 55°C
Environment temperature:

Kurzschlussfestigkeit (SCCR): 50kA
Short-circuit strength (SCCR):

Steuergerät:
Control device:

BK2300

Getriebemotor: 2x (24VDC/2A)
Gear motor:

Pumpenmotor: 1,3kW/3,16A
Pump motor:

weitere Hinweise:
other notes:

Kabeleinführung: Cable entry:
 oben top unten bottom

Hauptschalter: Main switch:
 vorne Front
 links left
 rechts right

Kundenvorschriften: Customer specifications:
 Ja Yes Nein No

REV05	Göricke	06.12.2024	Datum Date	22.02.2024		Hersteller Manufacturer Boll & Kirch Filterbau GmbH	Deckblatt Cover sheet Filtertyp 6.49 ME 2.0 DN65-DN100	BK-Artikel-Nr.: 4301025	=	
REV04	Göricke	15.10.2024	Bearbeiter Edited by	ogoericke				BK-Article-No.:	+	
REV03	Göricke	19.04.2024	Auftrag Order					Zeichnungs-Nr.: Z46857	Blatt Page	1
Revision Revision	Bearbeiter Edited by	Datum Date	Vorgang Process					Drawing-No.:	von of	24

Inhaltsverzeichnis Table of contents

Funktionskennzeichen function identifier	Einbauort Mounting location	Dokumentenart Document type	Seite Page	Seitenbezeichnung Page designation	Datum Date	Bearbeiter Edited by
		Schaltplan Wiring diagram	1	Deckblatt Cover sheet	05.12.2024	ogoericke
		Schaltplan Wiring diagram	2	Inhaltsverzeichnis Table of contents	12.12.2024	ogoericke
		Schaltplan Wiring diagram	3	Inhaltsverzeichnis Table of contents	06.12.2024	ogoericke
		Schaltplan Wiring diagram	4	Einspeisung und Stromversorgung Feed-in and power supply	06.12.2024	ogoericke
		Schaltplan Wiring diagram	5	Platine Circuit board	06.12.2024	ogoericke
		Schaltplan Wiring diagram	6	Bedienfeld + iBoll Modul Control panel + iBoll-Module	06.12.2024	ogoericke
		Schaltplan Wiring diagram	7	Getriebemotoren Gear motors	12.12.2024	ogoericke
		Schaltplan Wiring diagram	8	Pumpe Gear motors	05.12.2024	ogoericke
		Schaltplan Wiring diagram	9	Netzteil Gear motors	06.12.2024	ogoericke
		Schaltplan Wiring diagram	10	Ventil Valve	12.12.2024	ogoericke
		Schaltplan Wiring diagram	11	Sensoren Sensors	12.12.2024	ogoericke
		Schaltplan Wiring diagram	12	Reserve Spare	05.12.2024	ogoericke
		Schaltplan Wiring diagram	13	Aufbauplan Assembling diagram	06.12.2024	ogoericke
		Schaltplan Wiring diagram	14	Aufbauplan Klemmenbox Assembling diagram	05.12.2024	ogoericke
		Materialliste Part list	1	Materialliste Part list	12.12.2024	ogoericke
		Materialliste Part list	2	Materialliste Part list	05.12.2024	ogoericke
		Materialliste Part list	3	Materialliste Part list	12.12.2024	ogoericke
		Klemmenplan Terminal diagram	1	Klemmenplan Terminal diagram	05.12.2024	ogoericke
		Klemmenplan Terminal diagram	2	Klemmenplan Terminal diagram	05.12.2024	ogoericke
		Klemmenplan Terminal diagram	3	Klemmenplan Terminal diagram	06.12.2024	ogoericke

REV05	Göricke	06.12.2024	Datum Date	22.02.2024		Hersteller Manufacturer Boll & Kirch Filterbau GmbH	Inhaltsverzeichnis Table of contents Filtertyp 6.49 ME 2.0 DN65-DN100	BK-Artikel-Nr.: BK-Article-No.:	4301025	=
REV04	Göricke	15.10.2024	Bearbeiter Edited by	ogoericke				+ Blatt		
REV03	Göricke	19.04.2024	Auftrag Order					Page	2	
Revision Revision	Bearbeiter Edited by	Datum Date	Vorgang Process					von of	24	

Inhaltsverzeichnis Table of contents

Funktionskennzeichen function identifier	Einbauort Mounting location	Dokumentenart Document type	Seite Page	Seitenbezeichnung Page designation	Datum Date	Bearbeiter Edited by
		Klemmenplan Terminal diagram	4	Klemmenplan Terminal diagram	06.12.2024	ogoericke
		Klemmenplan Terminal diagram	5	Klemmenplan Terminal diagram	05.12.2024	ogoericke
		Klemmenplan Terminal diagram	6	Klemmenplan Terminal diagram	05.12.2024	ogoericke
		Klemmenplan Terminal diagram	7	Klemmenplan Terminal diagram	05.12.2024	ogoericke

REV05	Göricke	06.12.2024	Datum Date	22.02.2024		Hersteller Manufacturer Boll & Kirch Filterbau GmbH	Inhaltsverzeichnis Table of contents Filtertyp 6.49 ME 2.0 DN65-DN100	BK-Artikel-Nr.: BK-Article-No.:	4301025	=
REV04	Göricke	15.10.2024	Bearbeiter Edited by	ogoericke				+		
REV03	Göricke	19.04.2024	Auftrag Order					Blatt Page	3	
Revision Revision	Bearbeiter Edited by	Datum Date	Vorgang Process					von of	24	

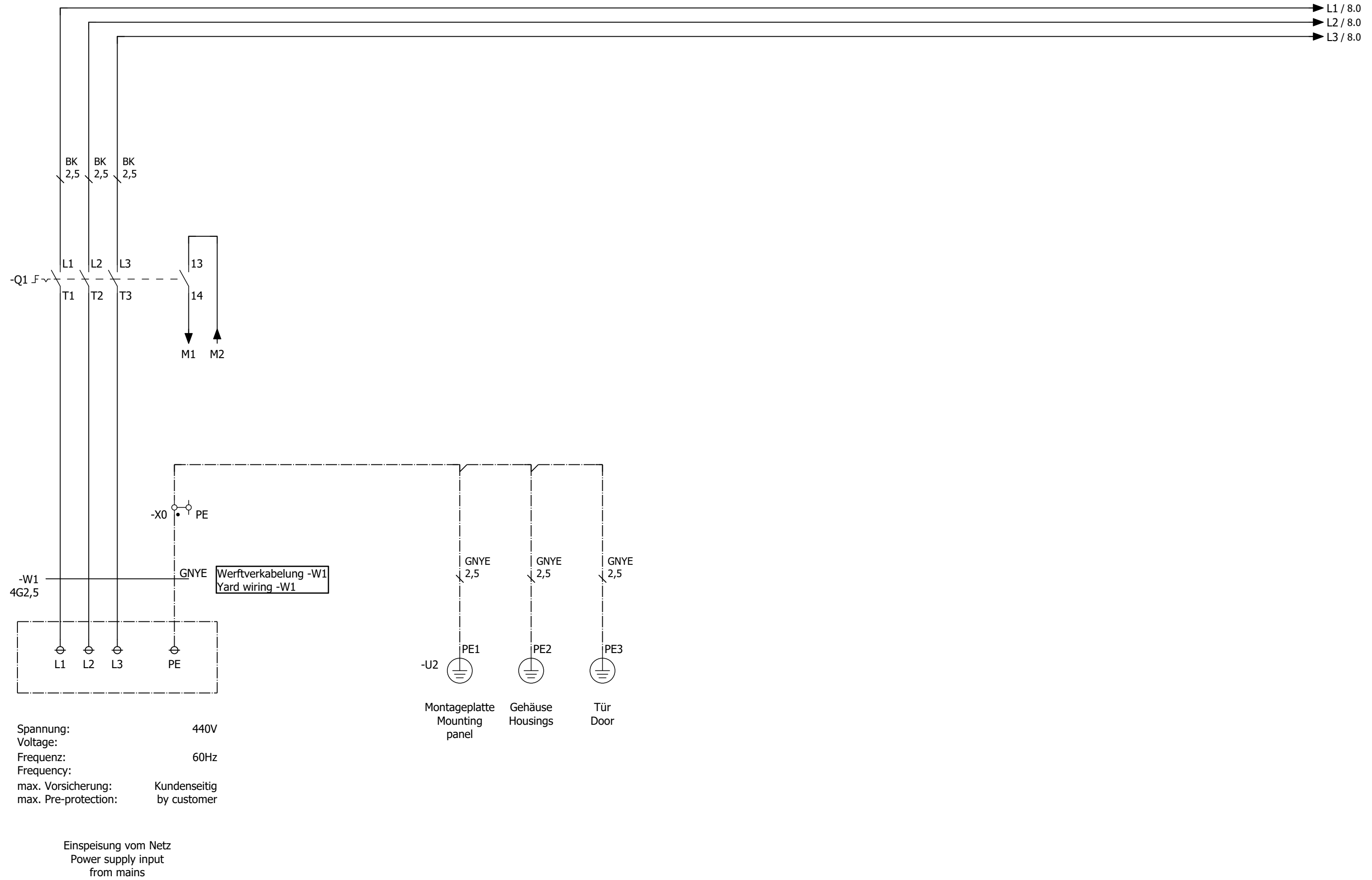

REV05	Göricke	06.12.2024	Datum Date	22.02.2024		Hersteller Manufacturer Boll & Kirch Filterbau GmbH	Einspeisung und Stromversorgung Feed-in and power supply Filtertyp 6.49 ME 2.0 DN65-DN100	BK-Artikel-Nr.: 4301025	=	
REV04	Göricke	15.10.2024	Bearbeiter Edited by	ogoeरिकke				BK-Article-No.:	+	
REV03	Göricke	19.04.2024	Auftrag Order					Zeichnungs-Nr.: Z46857	Blatt Page	4
Revision Revision	Bearbeiter Edited by	Datum Date	Vorgang Process					Drawing-No.:	von of	24

Hinweis für alle Klemmen der Platine -A2:
 Leiterquerschnitt flexibel, mit Aderendhülse mit Kunststoffhülse: max. 1,5mm²
 Note for all terminals from circuit board -A2:
 Conductor cross section flexible, with ferrule with plastic sleeve: max. 1,5mm²

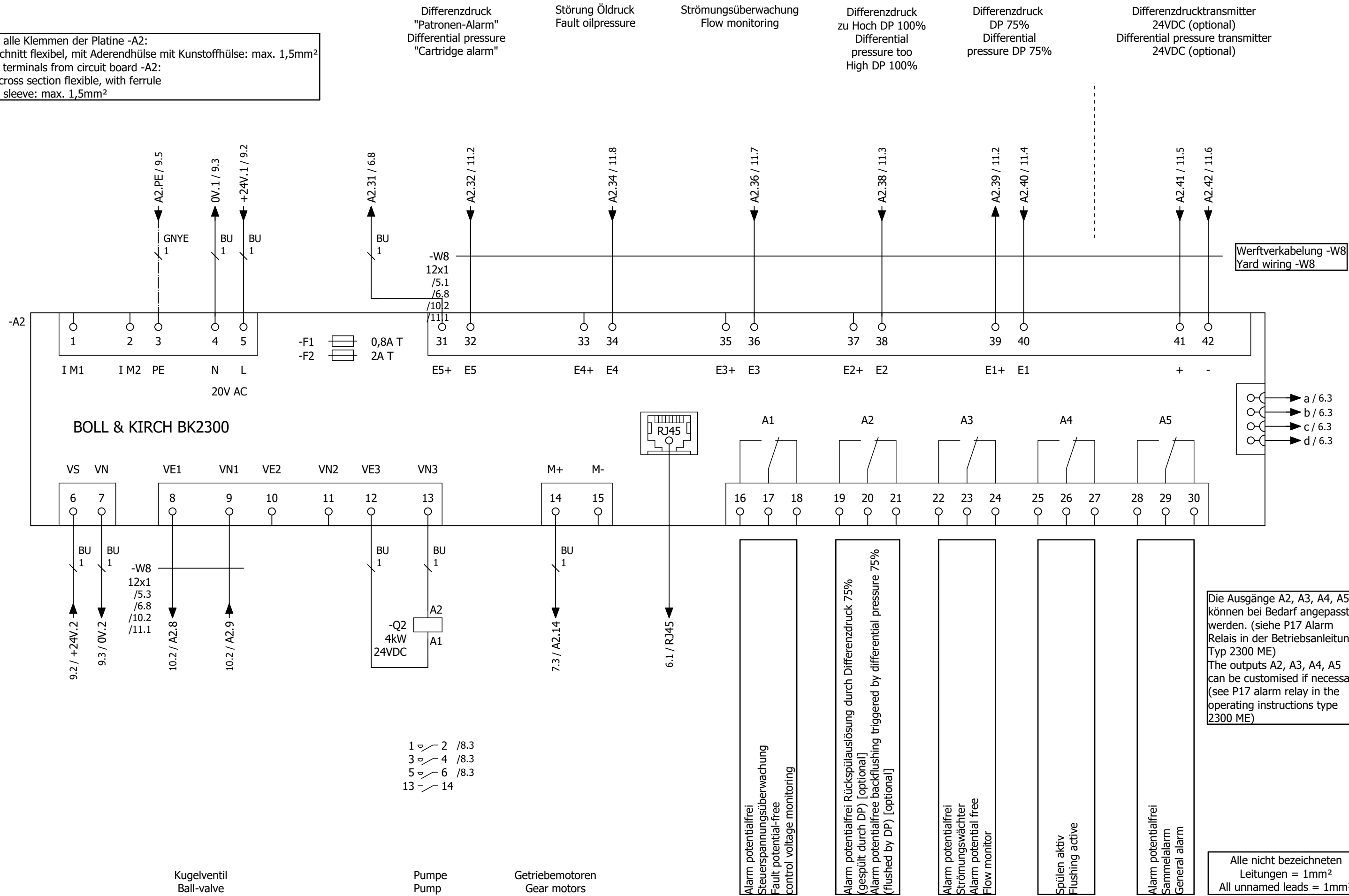

Die Ausgänge A2, A3, A4, A5 können bei Bedarf angepasst werden. (siehe P17 Alarm Relais in der Betriebsanleitung Typ 2300 ME)
 The outputs A2, A3, A4, A5 can be customised if necessary. (see P17 alarm relay in the operating instructions type 2300 ME)

Alle nicht bezeichneten Leitungen = 1mm²
 All unnamed leads = 1mm²

REV05	Göricke	06.12.2024	Datum Date	22.02.2024		Hersteller Manufacturer Boll & Kirch Filterbau GmbH	Platine Circuit board Filtertyp 6.49 ME 2.0 DN65-DN100	BK-Artikel-Nr.: BK-Article-No.:	4301025	=			
REV04	Göricke	15.10.2024	Bearbeiter Edited by	ogoeरिकe							+		
REV03	Göricke	19.04.2024	Auftrag Order							Zeichnungs-Nr.: Drawing-No.:	Z46857	Blatt Page	5
Revision Revision	Bearbeiter Edited by	Datum Date	Vorgang Process									von of	24

Störung Getriebemotor 1
Fault gear motor 1

Störung Getriebemotor 2
Fault gear motor 2

Störung Pumpe
Fault pump

Störung 3-Wege Ventil
3-way valve fault

Hinweis für Klemme 57:
Leiterquerschnitt flexibel,
mit Aderendhülse mit Kunststoffhülse:
max. 1,5mm²
Note for terminal 57:
Conductor cross section flexible, with ferrule with
plastic sleeve: max. 1,5mm²

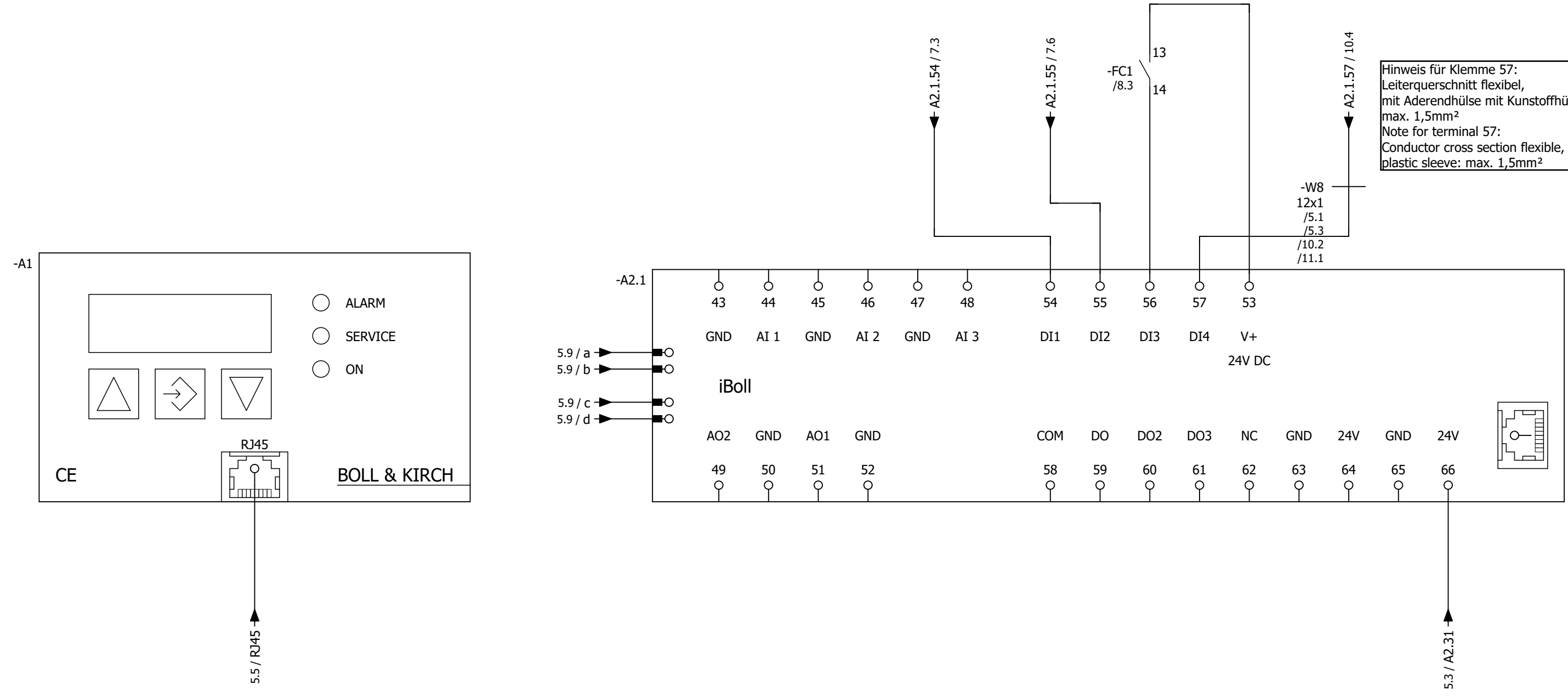

Platinensatz für Typ 2300 ME V2.0
(bestehend aus: Display -A1 / Platine -A2 / Zusatzplatine -A2.1 / Verbindungskabel)
Card-set for Type 2300 ME V2.0
(consisting of: display -A1 / circuit board -A2/ additional circuit board -A2.1 / connection cable)
B&K ID 4301028

Alle nicht bezeichneten
Leitungen = 1mm²
All unnamed leads = 1mm²

REV05	Göricke	06.12.2024	Datum Date	22.02.2024		Hersteller Manufacturer Boll & Kirch Filterbau GmbH	Bedienfeld + iBoll Modul Control panel + iBoll-Module Filtertyp 6.49 ME 2.0 DN65-DN100	BK-Artikel-Nr.: BK-Article-No.:	4301025	=
REV04	Göricke	15.10.2024	Bearbeiter Edited by	ogoericke				+ Blatt Page	6	
REV03	Göricke	19.04.2024	Auftrag Order					von of	24	
Revision Revision	Bearbeiter Edited by	Datum Date	Vorgang Process							
								Zeichnungs-Nr.: Drawing-No.:	Z46857	

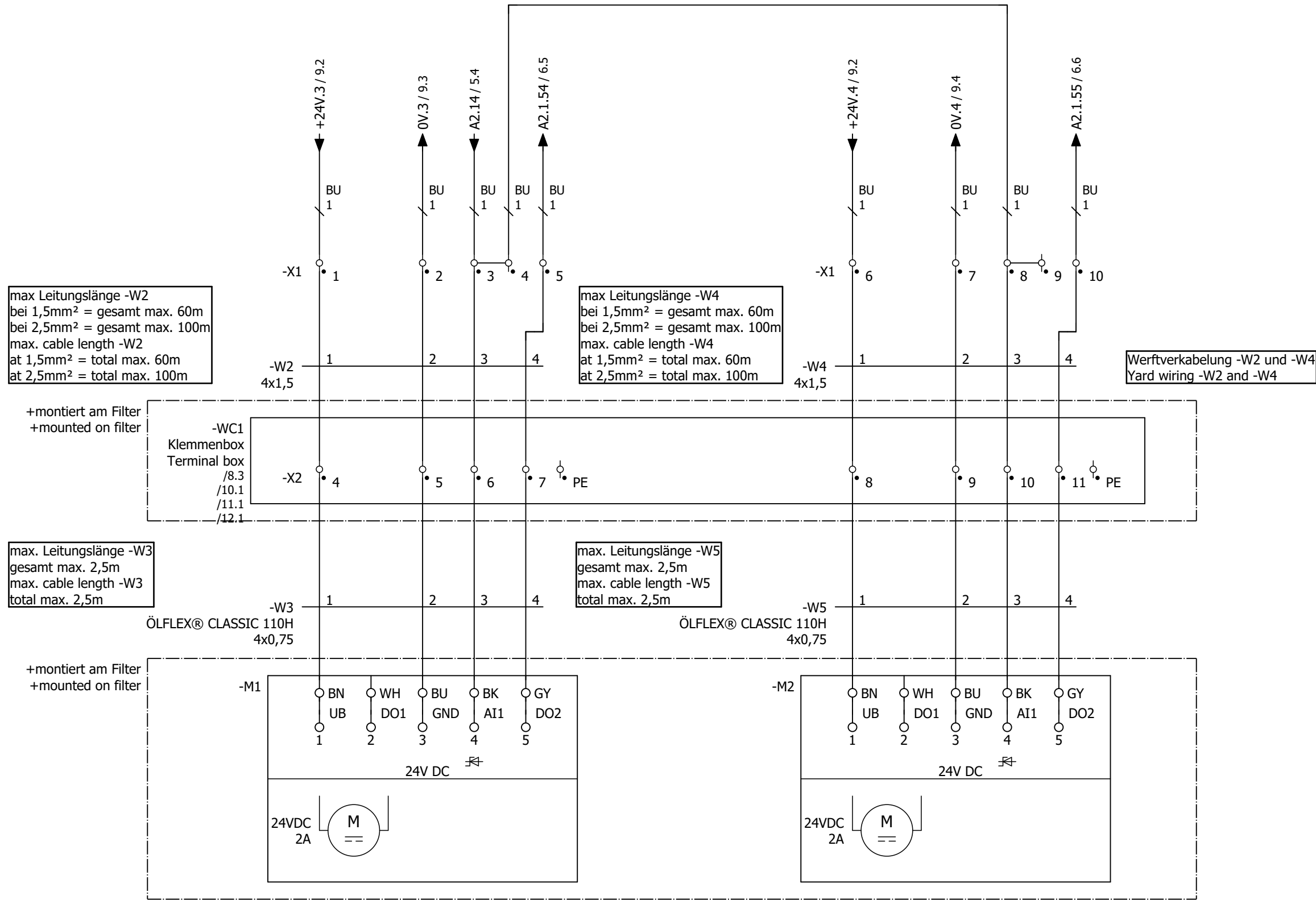

max Leitungslänge -W2
bei 1,5mm² = gesamt max. 60m
bei 2,5mm² = gesamt max. 100m
max. cable length -W2
at 1,5mm² = total max. 60m
at 2,5mm² = total max. 100m

max Leitungslänge -W4
bei 1,5mm² = gesamt max. 60m
bei 2,5mm² = gesamt max. 100m
max. cable length -W4
at 1,5mm² = total max. 60m
at 2,5mm² = total max. 100m

Wertverkabelung -W2 und -W4
Yard wiring -W2 and -W4

max. Leitungslänge -W3
gesamt max. 2,5m
max. cable length -W3
total max. 2,5m

max. Leitungslänge -W5
gesamt max. 2,5m
max. cable length -W5
total max. 2,5m

Getriebemotor 1
Gear motor 1

Getriebemotor 2
Gear motor 2

Alle nicht bezeichneten
Leitungen = 1mm²
All unnamed leads = 1mm²

REV05	Göricke	06.12.2024	Datum Date	22.02.2024		Hersteller Manufacturer Boll & Kirch Filterbau GmbH	Getriebemotoren Gear motors Filtertyp 6.49 ME 2.0 DN65-DN100	BK-Artikel-Nr.: BK-Article-No.:	4301025	=			
REV04	Göricke	15.10.2024	Bearbeiter Edited by	ogoeरिकe							+		
REV03	Göricke	19.04.2024	Auftrag Order							Zeichnungs-Nr.: Drawing-No.:	Z46857	Blatt Page	7
Revision Revision	Bearbeiter Edited by	Datum Date	Vorgang Process									von of	24

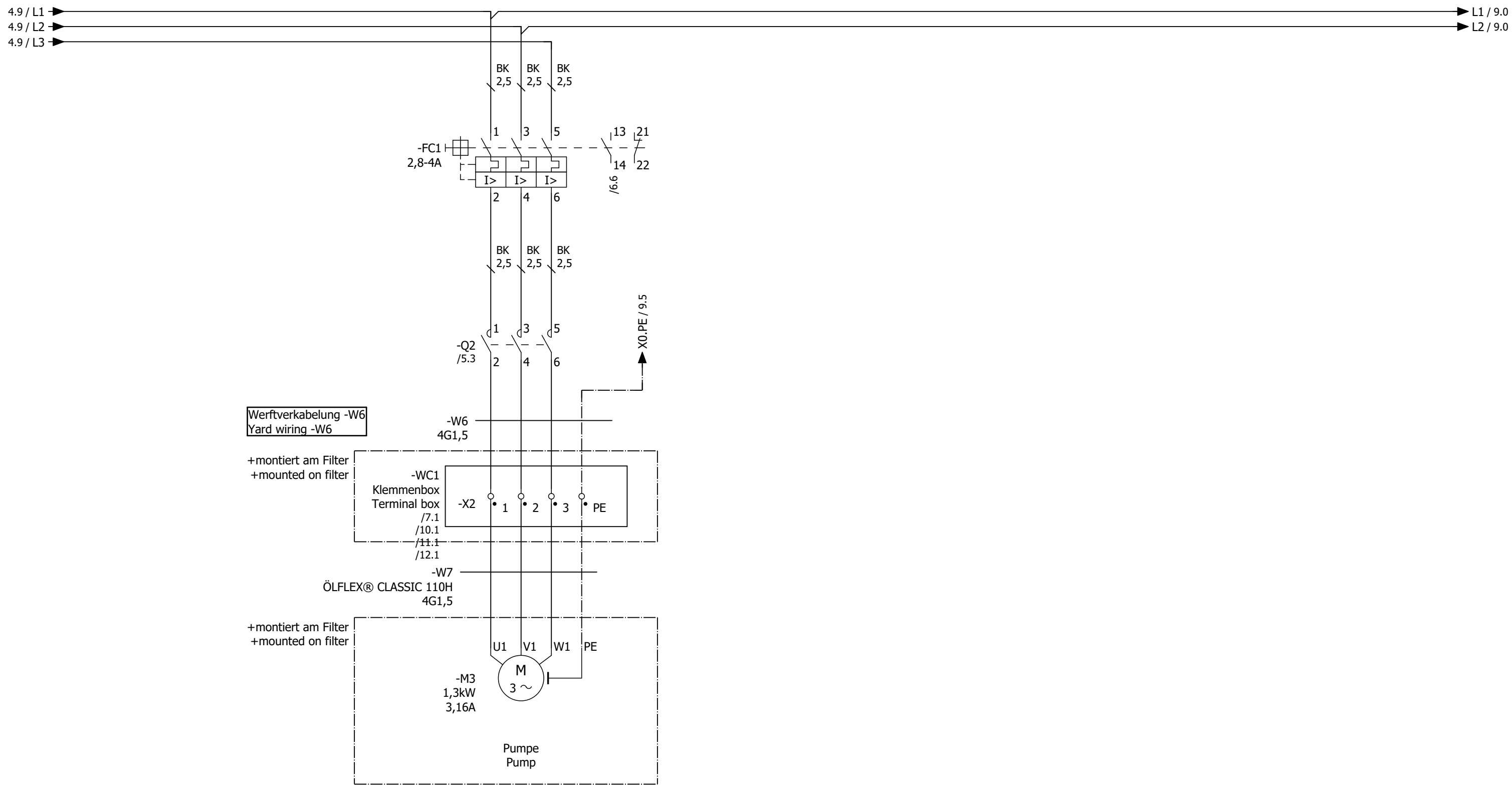

Werftverkabelung -W6
Yard wiring -W6

+montiert am Filter
+mounted on filter

+montiert am Filter
+mounted on filter

Alle nicht bezeichneten
Leitungen = 1mm²
All unnamed leads = 1mm²

REV05	Göricke	06.12.2024	Datum Date	22.02.2024		Hersteller Manufacturer Boll & Kirch Filterbau GmbH	Pumpe Gear motors Filtertyp 6.49 ME 2.0 DN65-DN100	BK-Artikel-Nr.: BK-Article-No.:	4301025	=			
REV04	Göricke	15.10.2024	Bearbeiter Edited by	ogoeरिके							+		
REV03	Göricke	19.04.2024	Auftrag Order							Zeichnungs-Nr.: Drawing-No.:	Z46857	Blatt Page	8
Revision Revision	Bearbeiter Edited by	Datum Date	Vorgang Process									von of	24

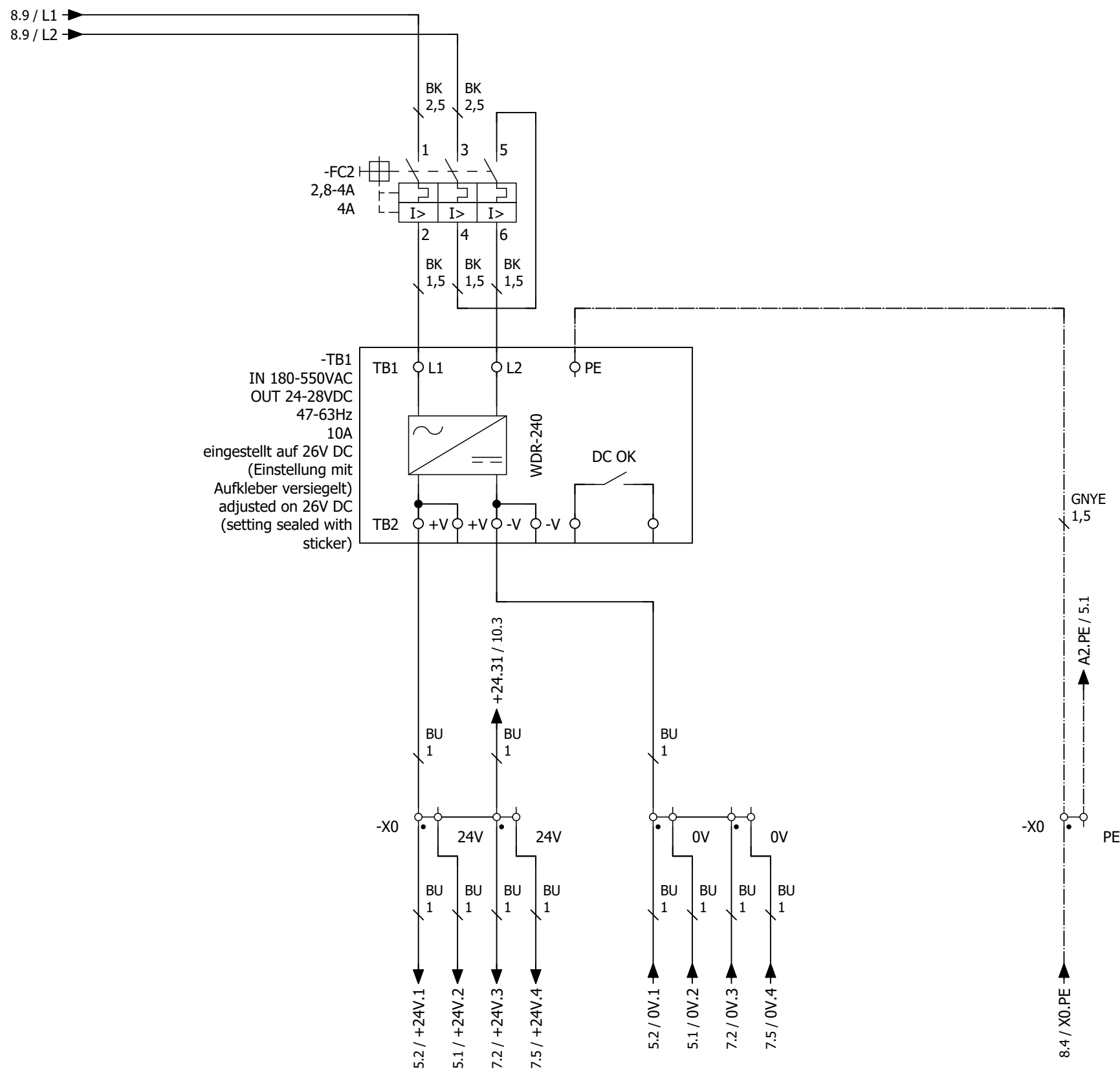

Alle nicht bezeichneten
Leitungen = 1mm²
All unnamed leads = 1mm²

REV05	Göricke	06.12.2024	Datum Date	22.02.2024		Hersteller Manufacturer	Netzteil Gear motors	BK-Artikel-Nr.: BK-Article-No.:	4301025	=			
REV04	Göricke	15.10.2024	Bearbeiter Edited by	ogoeरिके		Boll & Kirch Filterbau GmbH	Filtertyp 6.49 ME 2.0 DN65-DN100	Zeichnungs-Nr.: Drawing-No.:	Z46857	+			
REV03	Göricke	19.04.2024	Auftrag Order									Blatt Page	9
Revision Revision	Bearbeiter Edited by	Datum Date	Vorgang Process									von of	24

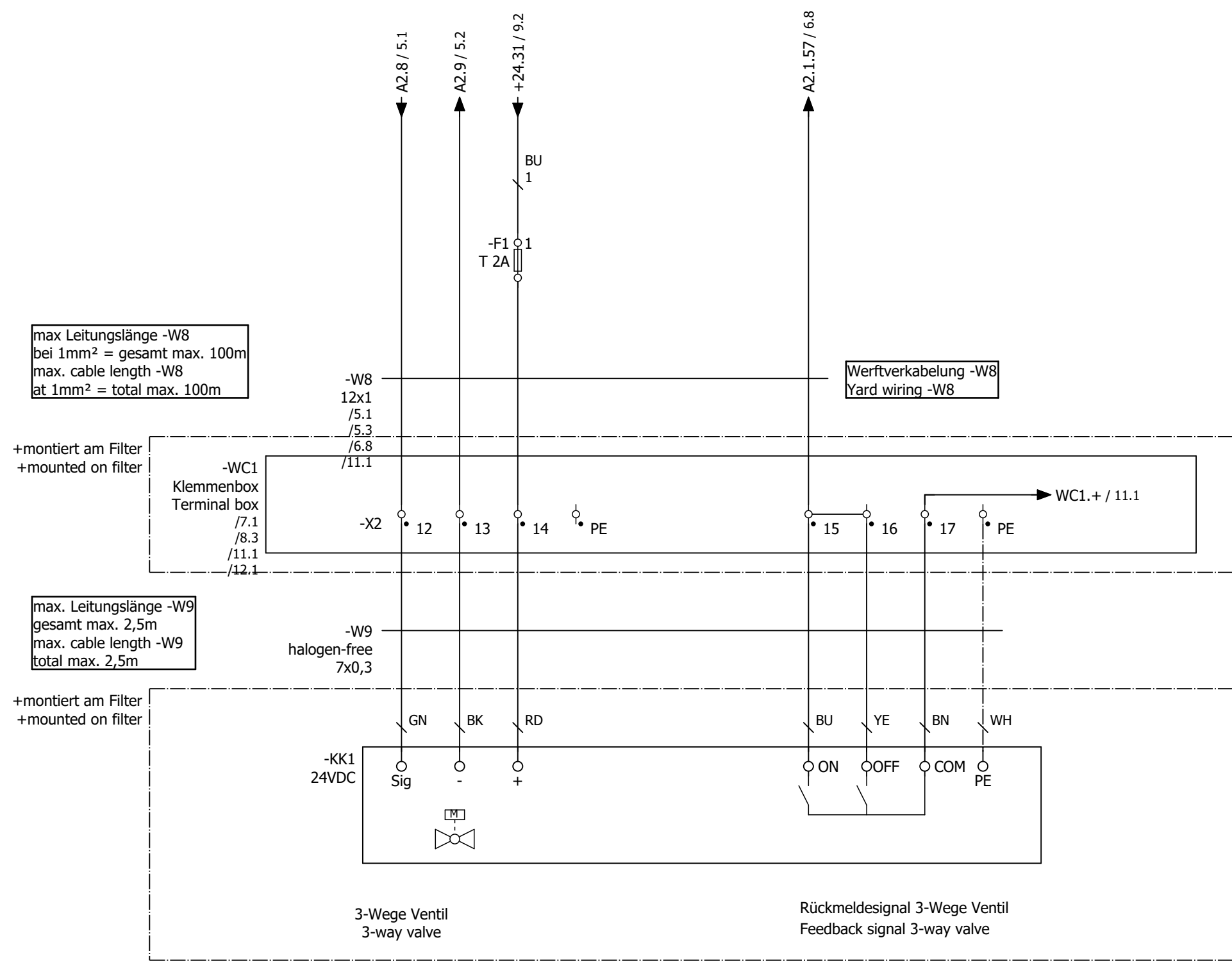

Alle nicht bezeichneten
Leitungen = 1mm²
All unnamed leads = 1mm²

REV05	Göricke	06.12.2024	Datum Date	22.02.2024		Hersteller Manufacturer Boll & Kirch Filterbau GmbH	Ventil Valve Filtertyp 6.49 ME 2.0 DN65-DN100	BK-Artikel-Nr.: BK-Article-No.:	4301025	=
REV04	Göricke	15.10.2024	Bearbeiter Edited by	ogoeरिके				Zeichnungs-Nr.: Drawing-No.:	Z46857	+
REV03	Göricke	19.04.2024	Auftrag Order							Blatt Page
Revision Revision	Bearbeiter Edited by	Datum Date	Vorgang Process					von of	24	

max Leitungslänge -W8
bei 1mm² = gesamt max. 100m
max. cable length -W8
at 1mm² = total max. 100m

Wertverkabelung -W8
Yard wiring -W8

+montiert am Filter
+mounted on filter

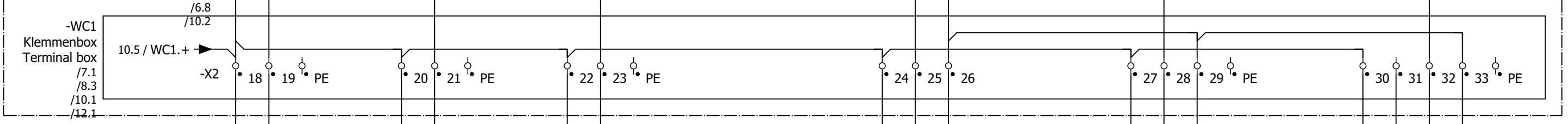

+montiert am Filter
+mounted on filter

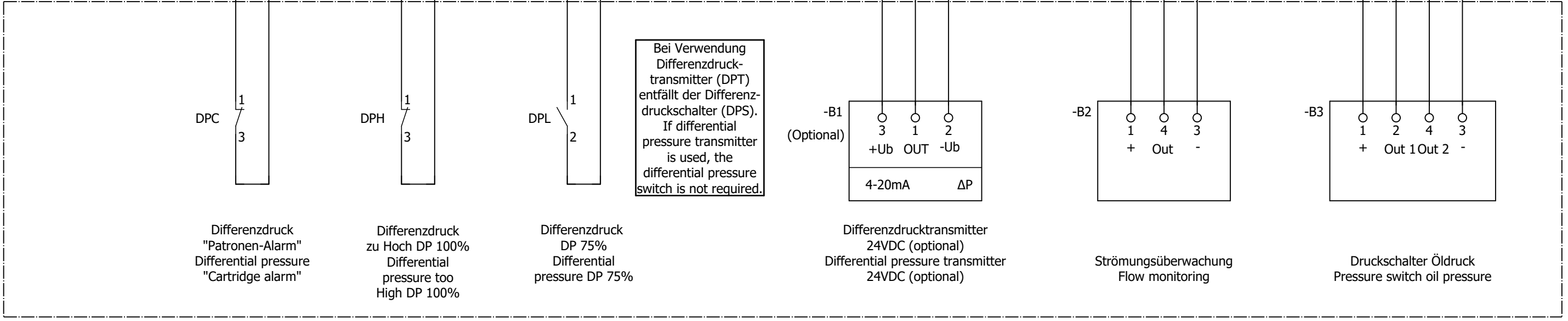

Alle nicht bezeichneten
Leitungen = 1mm²
All unnamed leads = 1mm²

REV05	Göricke	06.12.2024	Datum Date	22.02.2024		Hersteller Manufacturer Boll & Kirch Filterbau GmbH	Sensoren Sensors Filtertyp 6.49 ME 2.0 DN65-DN100	BK-Artikel-Nr.: BK-Article-No.:	4301025	=		
REV04	Göricke	15.10.2024	Bearbeiter Edited by	ogoeरिकe							+	
REV03	Göricke	19.04.2024	Auftrag Order								Blatt Page	11
Revision Revision	Bearbeiter Edited by	Datum Date	Vorgang Process								Zeichnungs-Nr.: Drawing-No.:	Z46857

+montiert am Filter
+mounted on filter

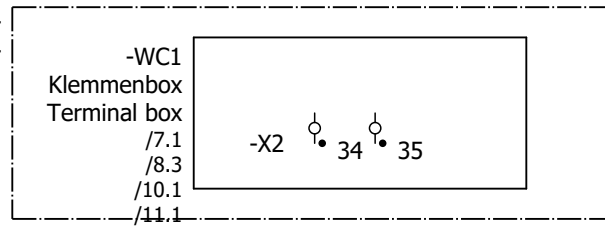

Reserve
Spare

Alle nicht bezeichneten
Leitungen = 1mm²
All unnamed leads = 1mm²

REV05	Göricke	06.12.2024	Datum Date	22.02.2024		Hersteller Manufacturer Boll & Kirch Filterbau GmbH	Reserve Spare Filtertyp 6.49 ME 2.0 DN65-DN100	BK-Artikel-Nr.: BK-Article-No.:	4301025	=
REV04	Göricke	15.10.2024	Bearbeiter Edited by	ogoericke				+		
REV03	Göricke	19.04.2024	Auftrag Order					Blatt Page	12	
Revision Revision	Bearbeiter Edited by	Datum Date	Vorgang Process					Zeichnungs-Nr.: Drawing-No.:	Z46857	von of

Unterseite
Bottom side

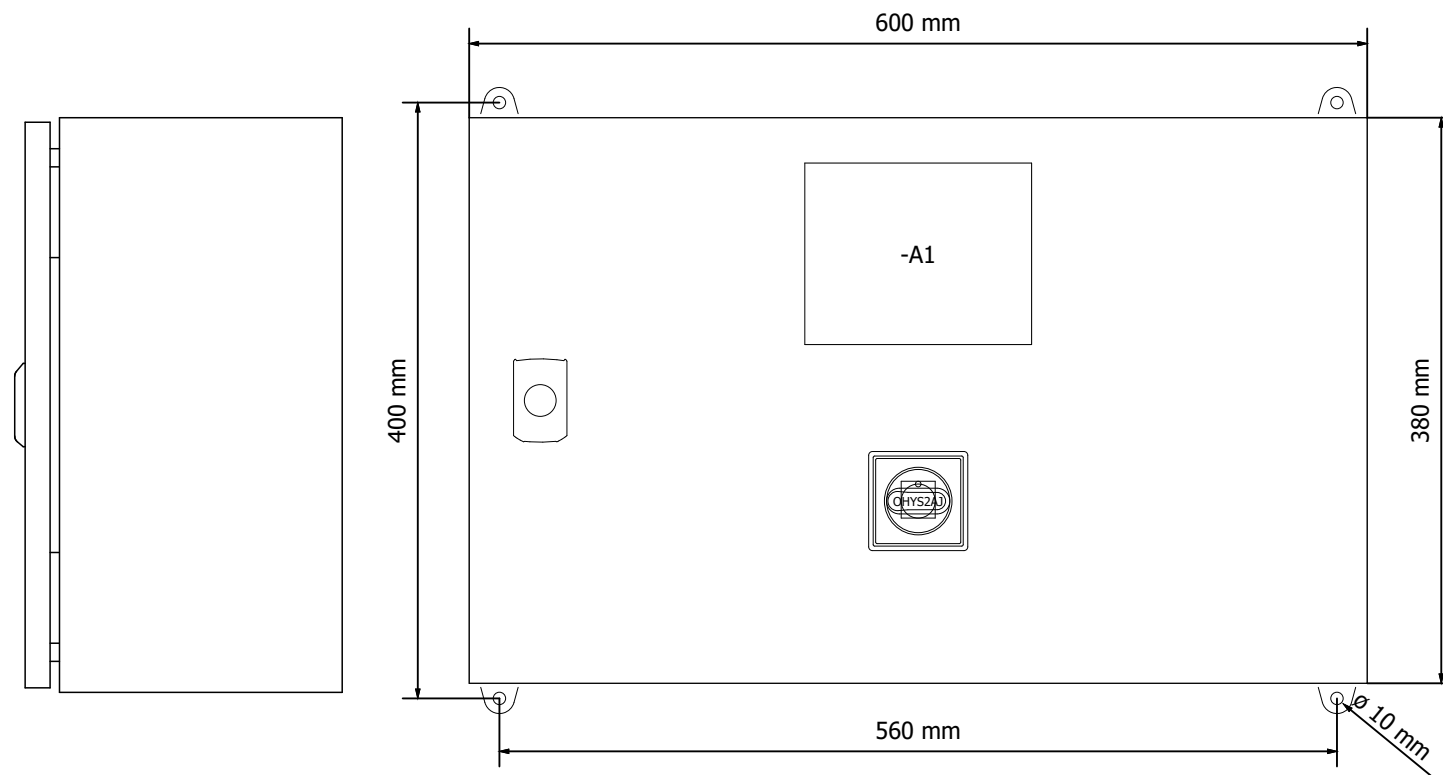
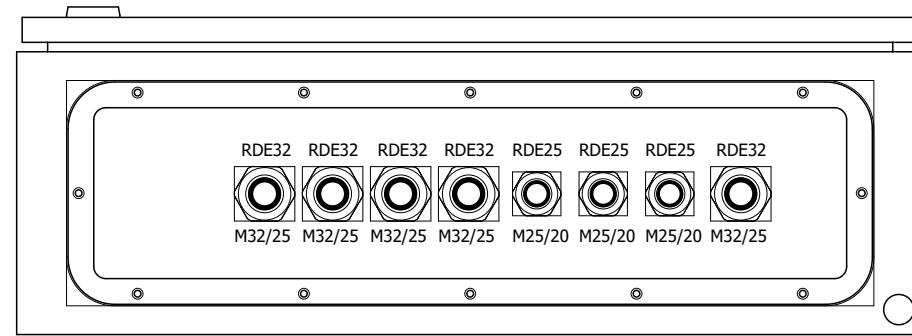

Oberseite
Topside

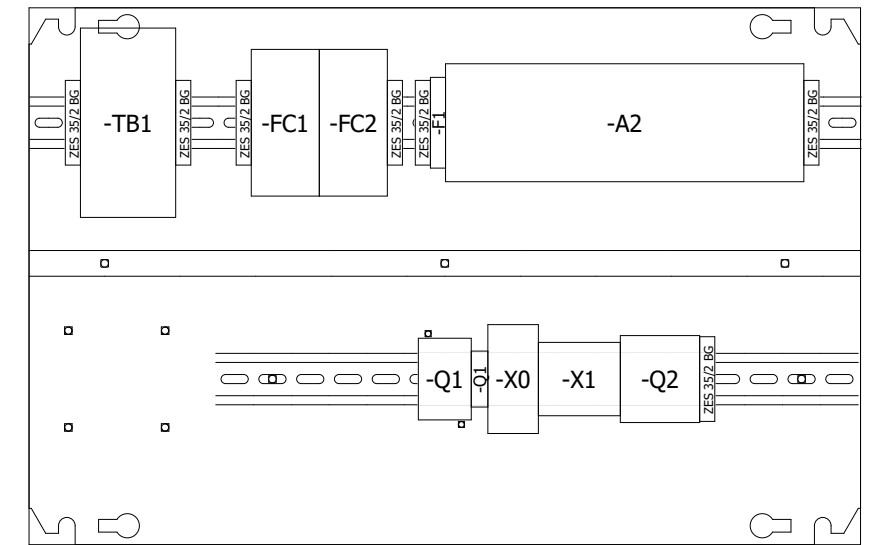
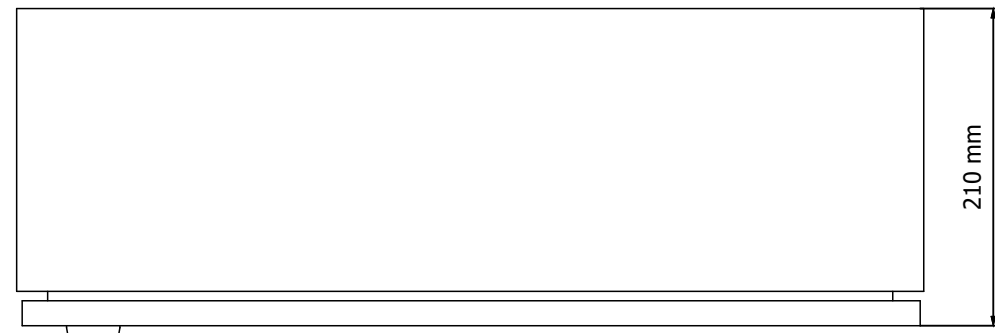

Reserve Sicherungssatz (bestehend aus: -A2-F1 / -A2-F1 / -F1)
Reserve fuse set (consisting of: -A2-F1 / -A2-F2 / -F1)
B&K ID 4301081

REV05	Göricke	06.12.2024	Datum Date	22.02.2024		Hersteller Manufacturer	Aufbauplan Assembling diagram	BK-Artikel-Nr.: BK-Article-No.:	4301025	=	
REV04	Göricke	15.10.2024	Bearbeiter Edited by	ogoeरिके		Boll & Kirch Filterbau GmbH	Filtertyp 6.49 ME 2.0 DN65-DN100	Zeichnungs-Nr.: Drawing-No.:	Z46857	+	
REV03	Göricke	19.04.2024	Auftrag Order							Blatt Page	13
Revision Revision	Bearbeiter Edited by	Datum Date	Vorgang Process							von of	24

- 1 Kabelverschraubung 1 für Pumpe -M3
EMSKV20 + RDE20 (Wiska)
Cable gland 1 for pump -M3
EMSKV20 + RDE20 (Wiska)
- 2 Kabelverschraubung 2 für 3-Wege-Kugelventil -KK1
EMSKV20 + RDE20 (Wiska)
Cable gland 2 for 3-way ball valve -KK1
EMSKV20 + RDE20 (Wiska)
- 3 Kabelverschraubung 3 für -B2 und -B3
EMSKV20 + MFD 20/02/050 (Wiska)
Cable gland 3 for -B2 and -B3
EMSKV20 + MFD 20/02/050 (Wiska)
- 4 Kabelverschraubung 4 für -M1 und -M2
EMSKV25 + MFD 25/02/070 (Wiska)
Cable gland 4 for -M1 and -M2
EMSKV25 + MFD 25/02/070 (Wiska)
- 5 Kabelverschraubung 5 für DPC + DPH + DPL
EMSKV25 + MFD 25/03/070 (Wiska)
Cable gland 5 for DPC + DPH + DPL
EMSKV25 + MFD 25/03/070 (Wiska)

Unterseite
Bottom side

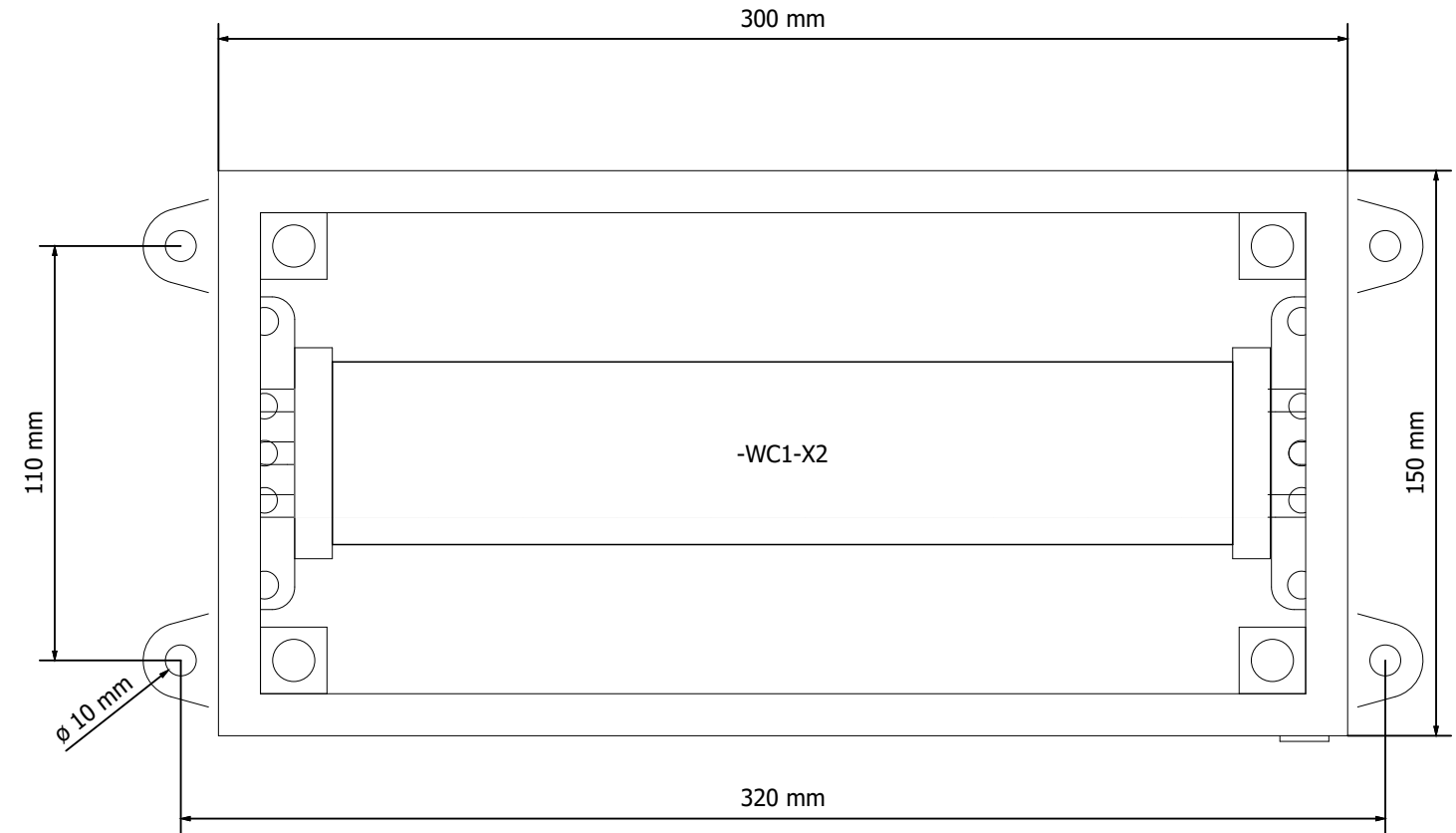
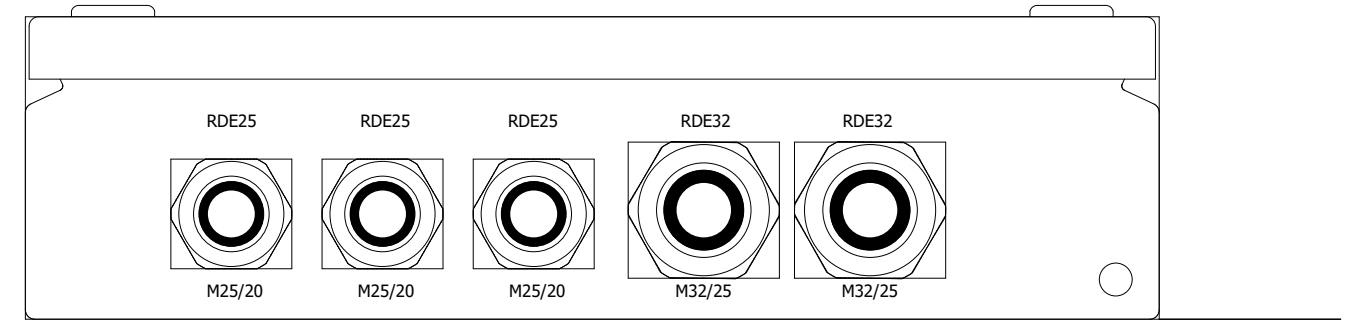

Oberseite
Topside

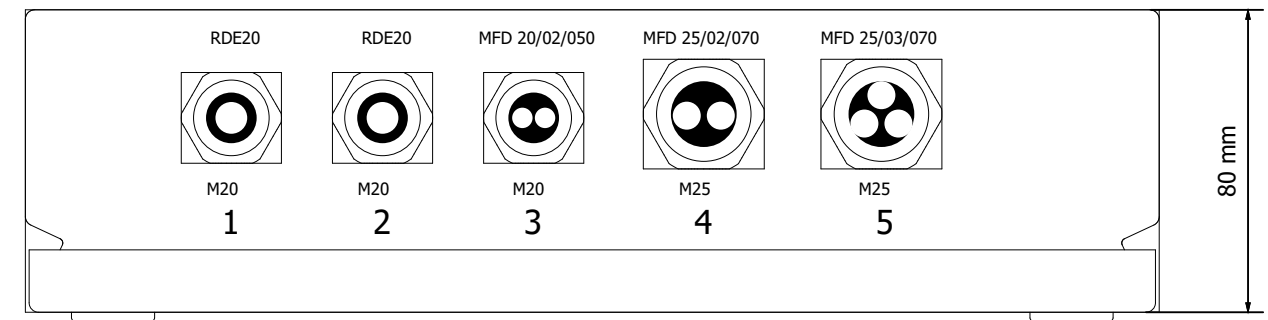

separater Klemmenkasten
Separate terminal box

B&K ID 4301033

Anschluß zu den elektrischen Bauteilen am Filter 6.49 ME
Connection to the electrical components on the filter 6.49 ME

REV05	Göricke	06.12.2024	Datum Date	22.02.2024		Hersteller Manufacturer	Aufbauplan Klemmenbox Assembling diagram	BK-Artikel-Nr.: BK-Article-No.:	4301025	=	
REV04	Göricke	15.10.2024	Bearbeiter Edited by	ogoericke		Boll & Kirch Filterbau GmbH	Filtertyp 6.49 ME 2.0 DN65-DN100	Zeichnungs-Nr.: Drawing-No.:	Z46857	+	
REV03	Göricke	19.04.2024	Auftrag Order							Blatt Page	14
Revision Revision	Bearbeiter Edited by	Datum Date	Vorgang Process							von of	24

Materialliste

Part list

Nr. No.	BMK DT	Anzahl Quant.	Bezeichnung Designation	Hersteller Manufacturer	Typ Type	Beschreibung Description	BK-Artikel-Nr.: BK-Article-No.:
1	-A1	1	Display	BOLL & KIRCH	BK2300	2 zeiliges universelles Display 2 lined universal Display	
2	-A1	1	Patchkabel Patch cable	Reco	SFTP	1m, RJ 45	4100403
3	-A2	1	E/A-Modul + iBoll I/O-Modul + iBoll	BOLL & KIRCH	BK2300+iBoll	ME 6.49 V2.0	4301028
4	-A2-F1	1	Schmelzsicherung Safety fuse	ESKA	522.516	0,8A, 5x20mm, Träge 0,8A, 5x20mm, Passive	4200162
5	-A2-F2	1	Schmelzsicherung Safety fuse	ESKA	522.520	2A, 5x20mm, Träge 2A, 5x20mm, Passive	4200163
6	-F1	1	Sicherungsklemme Fused terminal	Conta-Clip	SIK 10/Z BG	10 mm ² , NS35, Beige, Schraubanschluss 10 mm ² , NS35, Fawn, Screw terminal	4200526
7	-F1	2	Schmelzsicherung Safety fuse	ESKA	632.720	2A, 6,3x32mm, Träge 2A, 6,3x32mm, Passive	4201111
8	-FC1	1	Leistungsschalter Power circuit breaker	Siemens	3RV2011-1EA10	2,8-4A, BGR. S00, CLASS 10, Schraubanschluss 2,8-4A, BGR. S00, CLASS 10, Screw terminal	4200473
9	-FC1	1	Hilfsschalter Auxiliary switch	Siemens	3RV2901-1E	1NC+1NO, querliegend, für BGR. S00 / S0, Schraubanschluss 1NC+1NO, transversely, for BGR. S00 / S0, Screw terminal	4100257
10	-FC2	1	Leistungsschalter Power circuit breaker	Siemens	3RV2011-1EA10	2,8-4A, BGR. S00, CLASS 10, Schraubanschluss 2,8-4A, BGR. S00, CLASS 10, Screw terminal	4200473
11	-Q1	1	Lasttrennschalter Load interrupter	ABB	OT16F3	3 Polig, 16A, Bodenbefestigung 3 Pole, 16A, Bottom mounting	4200866
12	-Q1	1	Hilfskontakt Auxiliary contact	ABB	OA1G10	16A, 1NO, seitlich, für OT16...OT125 Hauptschalter 16A, 1NO, side mounting, for OT16...OT125 Main switch	4200617
13	-Q1	1	Hauptschaltergriff Main switch handle	ABB	OHYS2AJ	Rot/Gelb, IP65, NEMA 1 Red/Yellow, IP65, NEMA 1	4200866
14	-Q1	1	Hauptschalterwelle Main switch shaft	ABB	OXS6X180	180mm	4200866
15	-Q2	1	Leistungsschutz Power contactor	ABB	BC6-30-10	4kW, 1NO, 24VDC, Schraubanschluss 4kW, 1NO, 24VDC, Screw terminal	4200148
16	-TB1	1	Netzteil Power supply unit	Mean Well	WDR-240-24	IN 180-550VAC, 2 phasig, 47-63Hz, OUT 24-29VDC, 10A, 240W, UL508 IN 180-550VAC, 2 phase, 47-63Hz, OUT 24-29VDC, 10A, 240W, UL508	4200864
17	-U1	1	Wandschrank Wall cabinet	Rittal	AX 1039.199 Y289549	600 x 380 x 210mm, Stahl, RAL7035, bearbeitet 600 x 380 x 210mm, Steel, RAL7035, edited	4301094
18	-U1	1	Wandbefestigungshalter Wall mounting bracket	Rittal	KX 1590.010	10 mm, für AX und KX, Stahl 10 mm, for AX and KX, Steel	4300840
19	-U1	5	Kabelverschraubung Cable gland	WISKA	EMSKV 25-32 EMV-Z	M25, Messing, vernickelt, EMV-fest, Kabeldurchmesser 13-21mm M25, Brass, nickel-plated, EMC-proof, Cable diameter 13-21mm	4100098
20	-U1	5	Gegenmutter Locknut	WISKA	EMMU 25	M25, Messing, vernickelt M25, Brass, nickel-plated	4100310

REV05	Göricke	06.12.2024	Datum Date	22.02.2024		Hersteller Manufacturer Boll & Kirch Filterbau GmbH	Materialliste Part list Filtertyp 6.49 ME 2.0 DN65-DN100	BK-Artikel-Nr.: BK-Article-No.:	4301025	=
REV04	Göricke	15.10.2024	Bearbeiter Edited by	ogoeरिके				Zeichnungs-Nr.: Drawing-No.:	Z46857	+
REV03	Göricke	19.04.2024	Auftrag Order							Blatt Page
Revision Revision	Bearbeiter Edited by	Datum Date	Vorgang Process					von of	24	

Materialliste

Part list

Nr. No.	BMK DT	Anzahl Quant.	Bezeichnung Designation	Hersteller Manufacturer	Typ Type	Beschreibung Description	BK-Artikel-Nr.: BK-Article-No.:
21	-U1	5	Reduzierdichteinsatz Reduced seal insert	WISKA	RDE 32	Kabeldurchmesser 9-14mm, für M32 Kabelverschraubung Cable diameter 9-14mm, for M32 Cable gland	3250002
22	-U1	3	Kabelverschraubung Cable gland	WISKA	EMSKV 20-25 EMV-Z	M20, Messing, vernickelt, EMV-fest, Kabeldurchmesser 9-17mm M20, Brass, nickel-plated, EMC-proof, Cable diameter 9-17mm	4100097
23	-U1	3	Gegenmutter Locknut	WISKA	EMMU 20	M20, Messing, vernickelt M20, Brass, nickel-plated	4100309
24	-U1	3	Reduzierdichteinsatz Reduced seal insert	WISKA	RDE 25	Kabeldurchmesser 7-12mm, für M25 Kabelverschraubung Cable diameter 7-12mm, for M25 Cable gland	3250001
25	-U1	7	Endwinkel End angle	Conta-Clip	ZES 35/2 BG	Beige, für NS35 Tragschiene Fawn, for NS35 Mounting rail	4100311
26	-WC1-U2	1	Klemmenkasten Terminal box	Rittal	KX 1515.199 Y289548	300 x 150 x 80mm, Lackiert, RAL7035, IP65, bearbeitet 300 x 150 x 80mm, Lacquered, RAL7035, IP65, edited	4301095
27	-WC1-U2	1	Wandbefestigungshalter Wall mounting bracket	Rittal	KX 1590.010	10 mm, für AX und KX, Stahl 10 mm, for AX and KX, Steel	4300840
28	-WC1-U2	2	Kabelverschraubung Cable gland	WISKA	EMSKV 25-32 EMV-Z	M25, Messing, vernickelt, EMV-fest, Kabeldurchmesser 13-21mm M25, Brass, nickel-plated, EMC-proof, Cable diameter 13-21mm	4100098
29	-WC1-U2	3	Kabelverschraubung Cable gland	WISKA	EMSKV 20-25 EMV-Z	M20, Messing, vernickelt, EMV-fest, Kabeldurchmesser 9-17mm M20, Brass, nickel-plated, EMC-proof, Cable diameter 9-17mm	4100097
30	-WC1-U2	2	Kabelverschraubung Cable gland	WISKA	EMSKV 25	M25, Messing, vernickelt, GL UL M25, Brass, nickel-plated, GL UL	4100435
31	-WC1-U2	3	Kabelverschraubung Cable gland	WISKA	EMSKV 20	M20, Messing, vernickelt, GL UL M20, Brass, nickel-plated, GL UL	4100237
32	-WC1-U2	4	Gegenmutter Locknut	WISKA	EMMU 25	M25, Messing, vernickelt M25, Brass, nickel-plated	4100310
33	-WC1-U2	6	Gegenmutter Locknut	WISKA	EMMU 20	M20, Messing, vernickelt M20, Brass, nickel-plated	4100309
34	-WC1-U2	2	Reduzierdichteinsatz Reduced seal insert	WISKA	RDE 32	Kabeldurchmesser 9-14mm, für M32 Kabelverschraubung Cable diameter 9-14mm, for M32 Cable gland	3250002
35	-WC1-U2	3	Reduzierdichteinsatz Reduced seal insert	WISKA	RDE 25	Kabeldurchmesser 7-12mm, für M25 Kabelverschraubung Cable diameter 7-12mm, for M25 Cable gland	3250001
36	-WC1-U2	2	Reduzierdichteinsatz Reduced seal insert	WISKA	RDE 20	Kabeldurchmesser 4-8mm, für M20 Kabelverschraubung Cable diameter 4-8mm, for M20 Cable gland	3290017
37	-WC1-U2	1	Mehrfachdichteinsatz Multiple density insert	WISKA	MFD 20/02/050	für M20, 2 x 5mm for M20, 2 x 5mm	3250029
38	-WC1-U2	1	Mehrfachdichteinsatz Multiple density insert	WISKA	MFD 25/02/070	für M25, 2 x 7mm for M25, 2 x 7mm	3250028
39	-WC1-U2	1	Mehrfachdichteinsatz Multiple density insert	WISKA	MFD 25/03/070	für M25, 3 x 7mm for M25, 3 x 7mm	3250017
40	-WC1-U2	2	Endwinkel End angle	Conta-Clip	ZES 35/2 BG	Beige, für NS35 Tragschiene Fawn, for NS35 Mounting rail	4100311

REV05	Göricke	06.12.2024	Datum Date	22.02.2024		Hersteller Manufacturer Boll & Kirch Filterbau GmbH	Materialliste Part list Filtertyp 6.49 ME 2.0 DN65-DN100	BK-Artikel-Nr.: BK-Article-No.:	4301025	=	
REV04	Göricke	15.10.2024	Bearbeiter Edited by	ogoeरिके				Zeichnungs-Nr.: Drawing-No.:	Z46857	Blatt Page von of	16 24
REV03	Göricke	19.04.2024	Auftrag Order								
Revision Revision	Bearbeiter Edited by	Datum Date	Vorgang Process								

Materialliste

Part list

Nr. No.	BMK DT	Anzahl Quant.	Bezeichnung Designation	Hersteller Manufacturer	Typ Type	Beschreibung Description	BK-Artikel-Nr.: BK-Article-No.:
41	-WC1-X2	35	Durchgangsklemme Feed-through terminal block	Phoenix Contact	ST 2,5	2,5 mm ² , NS35, Grau, Zugfederanschluss 2,5 mm ² , NS35, Gray, Cage clamp connection	4100547
42	-WC1-X2	10	Schutzleiterklemme Protective conductor terminal	Phoenix Contact	ST 2,5-PE	4 mm ² , NS35, Grün/Gelb, Zugfederanschluss 4 mm ² , NS35, Green/Yellow, Cage clamp connection	4100548
43	-WC1-X2	2	Steckbrücke Plug-in bridge	Phoenix Contact	FBS 10-5	10er, 2,5mm ² Klemmen 10er, 2,5mm ² Terminals	4100558
44	-WC1-X2	1	Steckbrücke Plug-in bridge	Phoenix Contact	FBS 2-5	2er, für 2,5mm ² Klemmen 2er, for 2,5mm ² Terminals	4100554
45	-WC1-X2	1	Steckbrücke Plug-in bridge	Phoenix Contact	FBS 20-5	20er, für 2,5mm ² Klemmen 20er, for 2,5mm ² Terminals	4100559
46	-WC1-X2	1	Abschlussdeckel End cover	Phoenix Contact	D-ST 2,5	Grau, ST 2,5 Klemme Gray, ST 2,5 Terminal	4100119
47	-X0	2	Schutzleiterklemme Protective conductor terminal	Phoenix Contact	ST 2,5-QUATTRO-PE	2,5mm ² , NS35, Grün/Gelb, Zugfederanschluss 2,5mm ² , NS35, Green/Yellow, Cage clamp connection	4100550
48	-X0	4	Durchgangsklemme Feed-through terminal block	Phoenix Contact	ST 2,5-QUATTRO	4mm ² , NS35, Grau, Zugfederanschluss 4mm ² , NS35, Gray, Cage clamp connection	4100549
49	-X0	2	Steckbrücke Plug-in bridge	Phoenix Contact	FBS 2-5	2er, für 2,5mm ² Klemmen 2er, for 2,5mm ² Terminals	4100554
50	-X0	1	Abschlussdeckel End cover	Phoenix Contact	D-ST 2,5-QUATTRO	Grau Gray	4100551
51	-X1	10	Durchgangsklemme Feed-through terminal block	Phoenix Contact	ST 2,5	2,5 mm ² , NS35, Grau, Zugfederanschluss 2,5 mm ² , NS35, Gray, Cage clamp connection	4100547
52	-X1	2	Steckbrücke Plug-in bridge	Phoenix Contact	FBS 2-5	2er, für 2,5mm ² Klemmen 2er, for 2,5mm ² Terminals	4100554
53	-X1	1	Abschlussdeckel End cover	Phoenix Contact	D-ST 2,5	Grau, ST 2,5 Klemme Gray, ST 2,5 Terminal	4100119

REV05	Göricke	06.12.2024	Datum Date	22.02.2024		Hersteller Manufacturer Boll & Kirch Filterbau GmbH	Materialliste Part list Filtertyp 6.49 ME 2.0 DN65-DN100	BK-Artikel-Nr.: BK-Article-No.:	4301025	=
REV04	Göricke	15.10.2024	Bearbeiter Edited by	ogoeरिके				+ Blatt Page	17	
REV03	Göricke	19.04.2024	Auftrag Order					von of	24	
Revision Revision	Bearbeiter Edited by	Datum Date	Vorgang Process							

Klemmenplan Terminal diagram

Funktionstext Function text	Kabeltyp Cable type	Kabelname Cable name					-W8	= + #-F1						
								Zielbezeichnung Target designation		Klemme Terminal	Brücke Jumper	Zielbezeichnung Target designation		Blatt Page Pfad Path
								Bezeichnung Designation	Anschluss Connection			Bezeichnung Designation	Anschluss Connection	
3-Wege Ventil 3-way valve								-WC1-X2	14	1		-X0	24V	&1/10.3

REV05	Göricke	06.12.2024	Datum Date	22.02.2024		Hersteller Manufacturer	Klemmenplan Terminal diagram	BK-Artikel-Nr.: BK-Article-No.: 4301025	=	
REV04	Göricke	15.10.2024	Bearbeiter Edited by	ogoericke		Boll & Kirch Filterbau GmbH	Filtertyp 6.49 ME 2.0 DN65-DN100	Zeichnungs-Nr.: Drawing-No.: Z46857	+	
REV03	Göricke	19.04.2024	Auftrag Order						Blatt Page	18
Revision Revision	Bearbeiter Edited by	Datum Date	Vorgang Process						von of	24

Klemmenplan Terminal diagram

Funktionstext Function text	Kabelname Cable name	Kabeltyp Cable type	-W5	-W3	-W7	=+#-WC1-X2					-W2	-W4		
			ÖLFLEX® CLASSI C 110H	ÖLFLEX® CLASSI C 110H	ÖLFLEX® CLASSI C 110H	Zielbezeichnung Target designation		Zielbezeichnung Target designation						
			Bezeichnung Designation	Anschluss Connection	Klemme Terminal	Brücke Jumper	Bezeichnung Designation	Anschluss Connection	Blatt Page Pfad Path					
Pumpe Pump						-M3	U1	1	·	-Q2	2	&1/8.3		
Pumpe Pump						-M3	V1	2	·	-Q2	4	&1/8.3		
Pumpe Pump						-M3	W1	3	·	-Q2	6	&1/8.3		
Pumpe Pump						-M3	PE	PE	·	-X0	PE	&1/8.3		
Getriebemotor 1 Gear motor 1				1		-M1	BN	4	·	-X1	1	&1/7.2	1	
Getriebemotor 1 Gear motor 1				2		-M1	BU	5	·	-X1	2	&1/7.2	2	
Getriebemotor 1 Gear motor 1				3		-M1	BK	6	·	-X1	3	&1/7.3	3	
Getriebemotor 1 Gear motor 1				4		-M1	GY	7	·	-X1	5	&1/7.3	4	
								PE	·			&1/7.3		
Getriebemotor 2 Gear motor 2			1			-M2	BN	8	·	-X1	6	&1/7.5	1	
Getriebemotor 2 Gear motor 2			2			-M2	BU	9	·	-X1	7	&1/7.5	2	
Getriebemotor 2 Gear motor 2			3			-M2	BK	10	·	-X1	8	&1/7.6	3	
Getriebemotor 2 Gear motor 2			4			-M2	GY	11	·	-X1	10	&1/7.6	4	
								PE	·			&1/7.6		

REV05	Göricke	06.12.2024	Datum Date	22.02.2024		Hersteller Manufacturer	Klemmenplan Terminal diagram	BK-Artikel-Nr.: BK-Article-No.:	4301025	=	
REV04	Göricke	15.10.2024	Bearbeiter Edited by	ogoericke		Boll & Kirch Filterbau GmbH	Filtertyp 6.49 ME 2.0 DN65-DN100	Zeichnungs-Nr.: Drawing-No.:	Z46857	+	
REV03	Göricke	19.04.2024	Auftrag Order							Blatt Page	19
Revision Revision	Bearbeiter Edited by	Datum Date	Vorgang Process							von of	24

Klemmenplan Terminal diagram

Funktionstext Function text	Kabelname Cable name	Kabeltyp Cable type	-W12 ÖLFLEX® CLASSI C 110H	-W11 ÖLFLEX® CLASSI C 110H	-W9 halogen-free	=+#-WC1-X2						-W8
						Zielbezeichnung Target designation		Zielbezeichnung Target designation		Blatt Page Pfad Path		
						Bezeichnung Designation	Anschluss Connection	Klemme Terminal	Brücke Jumper		Bezeichnung Designation	
3-Wege Ventil 3-way valve					GN	-KK1	Sig	12	·	-A2	8	&1/10.2
3-Wege Ventil 3-way valve					BK	-KK1	-	13	·	-A2	9	&1/10.2
3-Wege Ventil 3-way valve					RD	-KK1	+	14	·	-F1	1	&1/10.3
3-Wege Ventil 3-way valve								PE	·			&1/10.3
3-Wege Ventil 3-way valve					BU	-KK1	ON	15		-A2.1	57	&1/10.4
3-Wege Ventil 3-way valve					YE	-KK1	OFF	16				&1/10.4
3-Wege Ventil 3-way valve					BN	-KK1	COM	17	·			&1/10.5
3-Wege Ventil 3-way valve					WH	-KK1	PE	PE	·			&1/10.5
Differenzdruck "Patronen-Alarm" Differential pressure "Cartridge alarm"							1	18	·	-A2	39	&1/11.2
Differenzdruck "Patronen-Alarm" Differential pressure "Cartridge alarm"							3	19	·	-A2	32	&1/11.2
Differenzdruck "Patronen-Alarm" Differential pressure "Cartridge alarm"								PE	·			&1/11.2
Differenzdruck "Patronen-Alarm" Differential pressure "Cartridge alarm"							1	20	·	-A2	39	&1/11.2
Differenzdruck zu Hoch DP 100% Differential pressure too High DP 100%							3	21	·	-A2	38	&1/11.3
Differenzdruck zu Hoch DP 100% Differential pressure too High DP 100%								PE	·			&1/11.3

REV05	Göricke	06.12.2024	Datum Date	22.02.2024		Hersteller Manufacturer	Klemmenplan Terminal diagram	BK-Artikel-Nr.: BK-Article-No.:	4301025	=
REV04	Göricke	15.10.2024	Bearbeiter Edited by	ogoericke		Boll & Kirch Filterbau GmbH	Filtertyp 6.49 ME 2.0 DN65-DN100	Zeichnungs-Nr.: Drawing-No.:	Z46857	+
REV03	Göricke	19.04.2024	Auftrag Order							Blatt Page
Revision Revision	Bearbeiter Edited by	Datum Date	Vorgang Process					von of	24	

Klemmenplan Terminal diagram

Funktionstext Function text	Kabelname Cable name	Kabeltyp Cable type	-W15 EVC187, M12, PU R, halogen-free	-W14 EVC187, M12, PU R, halogen-free	-W13 ÖLFLEX® CLASSI C 110H	=+#-WC1-X2					-W8		
						Zielbezeichnung Target designation						Zielbezeichnung Target designation	
						Bezeichnung Designation	Anschluss Connection	Klemme Terminal	Brücke Jumper	Bezeichnung Designation		Anschluss Connection	Blatt Page Pfad Path
Differenzdruck zu Hoch DP 100% Differential pressure too High DP 100%							1	22	•	•	&1/11.3		
Differenzdruck DP 75% Differential pressure DP 75%							2	23	•	•	-A2 40	&1/11.4	
Differenzdruck DP 75% Differential pressure DP 75%								PE	•	•	&1/11.4		
Differenzdrucktransmitter 24VDC (optional) Differential pressure transmitter 24VDC (optional)						-B1	3	24	•	•	&1/11.5		
Differenzdrucktransmitter 24VDC (optional) Differential pressure transmitter 24VDC (optional)						-B1	1	25	•	•	-A2 41	&1/11.5	
Differenzdrucktransmitter 24VDC (optional) Differential pressure transmitter 24VDC (optional)						-B1	2	26	•	•	-A2 42	&1/11.6	
Strömungsüberwachung Flow monitoring				BN		-B2	1	27	•	•	&1/11.7		
Strömungsüberwachung Flow monitoring				BK		-B2	4	28	•	•	-A2 36	&1/11.7	
Strömungsüberwachung Flow monitoring				BU		-B2	3	29	•	•	&1/11.7		
Strömungsüberwachung Flow monitoring								PE	•	•	&1/11.7		
Druckschalter Öldruck Pressure switch oil pressure			BN			-B3	1	30	•	•	&1/11.8		
Druckschalter Öldruck Pressure switch oil pressure			WH			-B3	2	31	•	•	&1/11.8		
Druckschalter Öldruck Pressure switch oil pressure			BK			-B3	4	32	•	•	-A2 34	&1/11.8	
Druckschalter Öldruck Pressure switch oil pressure			BU			-B3	3	33	•	•	&1/11.9		

REV05	Göricke	06.12.2024	Datum Date	22.02.2024		Hersteller Manufacturer	Klemmenplan Terminal diagram	BK-Artikel-Nr.: BK-Article-No.:	4301025	=	
REV04	Göricke	15.10.2024	Bearbeiter Edited by	ogoericke		Boll & Kirch Filterbau GmbH	Filtertyp 6.49 ME 2.0 DN65-DN100	Zeichnungs-Nr.: Drawing-No.:	Z46857	+	
REV03	Göricke	19.04.2024	Auftrag Order							Blatt Page	21
Revision Revision	Bearbeiter Edited by	Datum Date	Vorgang Process							von of	24

Klemmenplan Terminal diagram

=+#-WC1-X2

Funktionstext Function text	Kabelname Cable name	Zielbezeichnung Target designation		Zielbezeichnung Target designation				
	Kabeltyp Cable type	Bezeichnung Designation	Anschluss Connection	Klemme Terminal	Brücke Jumper	Bezeichnung Designation	Anschluss Connection	Blatt Page Pfad Path
	Druckschalter Öl Druck Pressure switch oil pressure				PE	·		
Reserve Spare				34	·			&1/12.2
Reserve Spare				35	·			&1/12.2

REV05	Göricke	06.12.2024	Datum Date	22.02.2024		Hersteller Manufacturer Boll & Kirch Filterbau GmbH	Klemmenplan Terminal diagram Filtertyp 6.49 ME 2.0 DN65-DN100	BK-Artikel-Nr.: BK-Article-No.:	4301025	=		
REV04	Göricke	15.10.2024	Bearbeiter Edited by	ogoericke				Zeichnungs-Nr.: Drawing-No.:	Z46857	+	Blatt Page	22
REV03	Göricke	19.04.2024	Auftrag Order							von	24	
Revision Revision	Bearbeiter Edited by	Datum Date	Vorgang Process					of				

Klemmenplan Terminal diagram

Funktionstext Function text	Kabelname Cable name	Kabeltyp Cable type	-W1	= + # -X0						
				Zielbezeichnung Target designation		Zielbezeichnung Target designation		Blatt Page Pfad Path		
				Bezeichnung Designation	Anschluss Connection	Klemme Terminal	Brücke Jumper		Bezeichnung Designation	Anschluss Connection
Einspeisung vom Netz Power supply input from mains			GNYE	-PE		PE	·	-U2	PE1	&1/4.1
				-A2;-A2	5;6	24V		-TB1	TB2:+V	&1/9.2
				-X1;-X1	1;6	24V		-F1	1	&1/9.2
				-A2;-A2	4;7	0V		-TB1	TB2:-V	&1/9.3
				-X1;-X1	2;7	0V				&1/9.3
				-WC1-X2;-A2	PE;3	PE	·	-TB1	TB1:PE	&1/9.5

REV05	Göricke	06.12.2024	Datum Date	22.02.2024		Hersteller Manufacturer	Klemmenplan Terminal diagram	BK-Artikel-Nr.: BK-Article-No.:	4301025	=	
REV04	Göricke	15.10.2024	Bearbeiter Edited by	ogoericke		Boll & Kirch Filterbau GmbH	Filtertyp 6.49 ME 2.0 DN65-DN100	Zeichnungs-Nr.: Drawing-No.:	Z46857	+	
REV03	Göricke	19.04.2024	Auftrag Order							Blatt Page	23
Revision Revision	Bearbeiter Edited by	Datum Date	Vorgang Process							von of	24

Klemmenplan Terminal diagram

Funktionstext Function text	Kabelname Cable name	Kabeltyp Cable type	-W4	-W2	= + # -X1						
					Zielbezeichnung Target designation		Zielbezeichnung Target designation		Blatt Page Pfad Path		
					Bezeichnung Designation	Anschluss Connection	Klemme Terminal	Brücke Jumper		Bezeichnung Designation	Anschluss Connection
Getriebemotor 1 Gear motor				1	-WC1-X2	4	1	·	-X0	24V	&1/7.2
Getriebemotor 1 Gear motor				2	-WC1-X2	5	2	·	-X0	0V	&1/7.2
Getriebemotor 1 Gear motor				3	-WC1-X2	6	3		-A2	14	&1/7.3
Getriebemotor 1 Gear motor 1							4		·		
Getriebemotor 1 Gear motor				4	-WC1-X2	7	5	·	-A2.1	54	&1/7.3
Getriebemotor 2 Gear motor			1		-WC1-X2	8	6	·	-X0	24V	&1/7.5
Getriebemotor 2 Gear motor			2		-WC1-X2	9	7	·	-X0	0V	&1/7.5
Getriebemotor 2 Gear motor			3		-WC1-X2	10	8				&1/7.6
Getriebemotor 2 Gear motor 2							9		·		
Getriebemotor 2 Gear motor			4		-WC1-X2	11	10	·	-A2.1	55	&1/7.6

REV05	Göricke	06.12.2024	Datum Date	22.02.2024		Hersteller Manufacturer	Klemmenplan Terminal diagram	BK-Artikel-Nr.: BK-Article-No.:	4301025	=	
REV04	Göricke	15.10.2024	Bearbeiter Edited by	ogoericke		Boll & Kirch Filterbau GmbH	Filtertyp 6.49 ME 2.0 DN65-DN100	Zeichnungs-Nr.: Drawing-No.:	Z46857	+	
REV03	Göricke	19.04.2024	Auftrag Order							Blatt Page	24
Revision Revision	Bearbeiter Edited by	Datum Date	Vorgang Process							von of	24